

# Altivar 68

## Telemecanique

User's manual

Variable speed controllers for asynchronous motors

75 ... 630 kW

400 ... 500 V

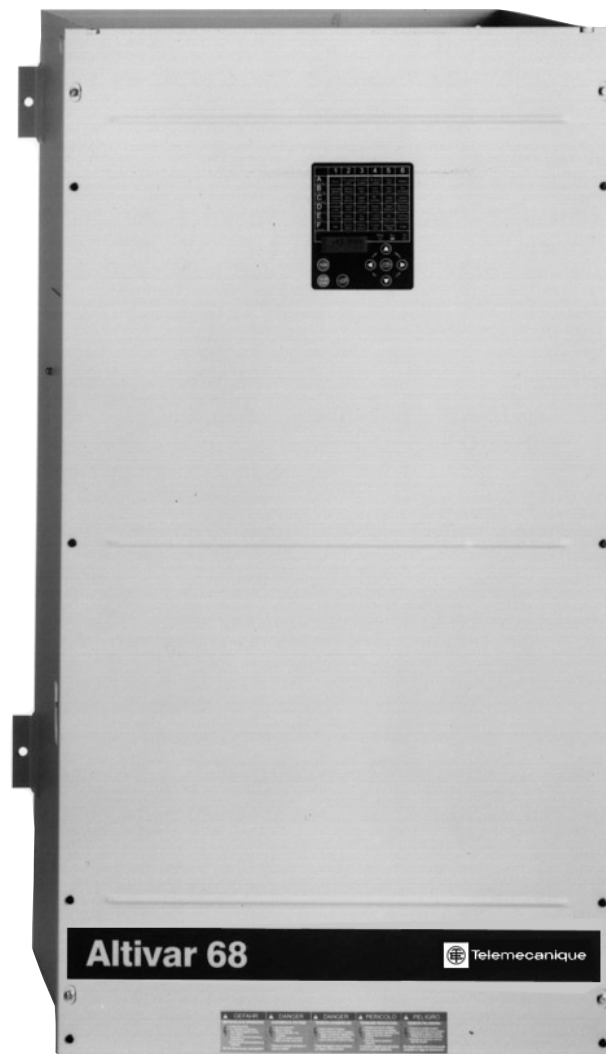

Merlín Gerín

Modicon

Square D

Telemecanique

**Schneider**  
 **Electric**

**ATTENTION**  
IT NEUTRAL POINT CONNECTION : In the event of use on a 3-phase plus neutral network with an isolated or high-impedance system (IT), radio interference suppression filters must not be fitted, use of an earth fault detection kit is required : see Options.

When the speed controller is powered up, the power components and some of the control components are connected to the line supply. *It is extremely dangerous to touch them. The speed controller cover must be kept closed.*

After switching the power to the ALTIVAR off, *wait for at least 5 minutes before working on the equipment.* This is the time required for the capacitors to discharge. In any case, voltage measurement on terminals + and – is required. Voltage must be less than 60 V DC.

As a rule, *the speed controller power supply must be switched-off before any operation* on either electrical or mechanical parts of the installation or machine.

The motor can be stopped during operation by inhibiting start commands or the speed reference while the speed controller remains powered up. If personnel safety requires prevention of sudden restarts, this electronic locking system is not sufficient : *install a device to interrupt the supply on the power circuit and any mechanical brakes.*

The speed controller can start automatically by configuration after switching on its power section. You must ensure that no persons or equipment are endangered.

The speed controller is fitted with safety devices which, in the event of a fault, can shut down the speed controller and consequently the motor. The motor itself may be stopped by a mechanical blockage. Finally, voltage variations, especially line supply failures, can also cause shutdowns. If the cause of the shutdown disappears, there is a risk of restarting which may endanger certain machines or installations, especially those which must conform to safety regulations. *In this case the user must take precautions against the possibility of restarts, in particular by using a low speed detector to interrupt the power to the speed controller if the motor is subject to an unprogrammed shutdown.*

Fault management can be carried out by the speed controller in various ways. Consult chapter E of the programming guide.

The design of equipment must conform to the requirements of IEC standards.

When supply of the speed controller is not by the power circuit (L1, L2, L3) but by the 24 volt auxiliary supply, the speed, temperature and output voltage information shown on the display is not available.

The products and equipment described in this document may be changed or modified at any time, either from a technical point of view or in the way they are operated. Their description can in no way be considered contractual.



## Warning

The Altivar 68 must be considered as a component: it is neither a machine nor a device ready for use in accordance with European directives (machinery directive and electromagnetic compatibility directive). It is the responsibility of the end user to ensure that the machine meets these directives.

The speed controller must be installed and set up conforming to the user manual and in accordance with both international and national standards. Bringing the device into conformity is the responsibility of the systems integrator who must observe, among others, the EMC and LV directives in its place of use within the European Community.

The specifications contained in this document must be applied in order to comply with the essential requirements of the EMC directive.

# Contents

---

<b>Preliminary recommendations / Speed controller - motor connection</b>	<b>4</b>
<b>Speed controller - motor connection</b>	<b>5</b>
<b>Available torque</b>	<b>6</b>
<b>Technical characteristics</b>	<b>7</b>
<b>Dimensions and fixing</b>	<b>9</b>
<b>Mounting recommendations</b>	<b>11</b>
<b>ATV-68 enclosure mounting</b>	<b>13</b>
<b>Access to terminals</b>	<b>14</b>
<b>Wiring diagrams for control terminals</b>	<b>16</b>
<b>Wiring diagrams: encoder feedback and RS232 link card terminals</b>	<b>20</b>
<b>Control terminal block characteristics</b>	<b>21</b>
<b>Power part wiring diagram</b>	<b>24</b>
<b>DC bus power connection diagrams</b>	<b>27</b>
<b>DC bus connection cable sections and fuses</b>	<b>29</b>
<b>Line cables and fuses</b>	<b>30</b>
<b>Special uses / IT network</b>	<b>31</b>
<b>Installation and maintenance</b>	<b>32</b>
<b>Options</b>	<b>33</b>

# Preliminary recommendations / Speed controller - motor connection

## Acceptance

Ensure that the speed controller reference printed on the label is the same as that on the delivery note corresponding to the purchase order.

Remove the Altivar 68 from its packaging and check that it has not been damaged in transit.

## Handling and storage

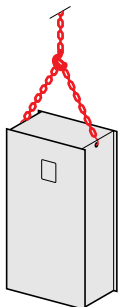

To ensure that the speed controller is protected before installation, handle and store the equipment in its packaging. The ATV-68 range includes 4 speed controller sizes of different weights and dimensions. Speed controllers are fitted with lifting eyes for easy lifting.

## Speed controller - motor connection

### Motor power

Currents of high power motors are not standardised and the rating of the speed controller associated with motor power is given as a guide only. It is necessary to **verify that the rated current of the motor used is compatible with the maximum rated output current of the speed controller.**

### Line current

The line current stated is with the additional line chokes. These values are indicative as they depend on line impedance. They are calculated from the maximum rated current of the speed controller.

### Electrical supply and use of line choke

Line chokes are mandatory, except for ratings ATV-68C10N4 to C33N4, if the impedance of line or transformer is higher than:

- 245  $\mu\text{H}$  for rating C10 N4,
- 120  $\mu\text{H}$  for ratings C13, C15 and C19 N4,
- 60  $\mu\text{H}$  for ratings C23, C28 and C33 N4.

In the case where speed controllers are directly interconnected on their power inputs L1, L2, L3 or with very close connections, wiring of additional line chokes is mandatory.

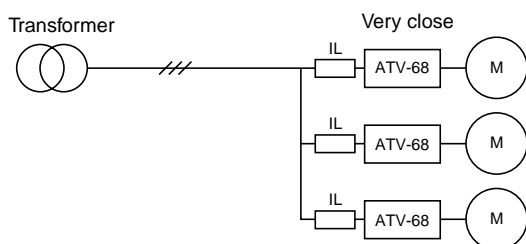

## ATV-68FC●●N4: flux vector speed controllers with sensors

ATV-68FC●●N4 controllers are standard controllers equipped with a factory-fitted and wired encoder feedback card. Only their torque characteristics are different. Their reference is completed by the letter F (eg. ATV-68F C10N4).

# Speed controller - motor connection

## High torque applications (150% of rated torque available in transient operation), for 75 kW to 500 kW motors

Supply voltage: 400 V -15%...500 V +10% 50 Hz ±5% 60 Hz ±5%

Motor Power rating on motor plate (1)		Mains				Altivar 68						References (7)
		Line current (2)				Maximum rated current				Maximum transient current (3)	Power dissipated at rated load (5)	
500 V 440 V 400 V	460 V	400 V	440 V	460 V	500 V	400 V	440 V	460 V	500 V			
kW	HP	A	A	A	A	A	A	A	A	A	W	
75	100	133	121	116	106	142	129	124	113	213	2050	ATV-68C10N4
90	125	161	146	146	129	172	156	156	137	258	2400	ATV-68C13N4
110	150	194	177	169	157	208	189	180	167	312	2800	ATV-68C15N4
132	200	234	224	225	188	250	240	240	200	375	3250	ATV-68C19N4
160	250	304	282	283	244	325	302	302	260	488	4000	ATV-68C23N4
200	300	378	343	338	304	404	367	361	323	606	5000	ATV-68C28N4
250	350	444	403	388	357	475	431	414	380	713	6200	ATV-68C33N4
315	500	577	552	553	464	617	590	590	494	926	7800	ATV-68C43N4
400	600	717	673	675	577	767	720	720	614	1151	9700	ATV-68C53N4
500	800	845	785	787	680	904	840	840	723	1356	12000	ATV-68C63N4

## Standard torque applications (variable torque applications, 120% of rated torque in transient operation), for 90 kW to 630 kW motors

Supply voltage: 400 V -15%...500 V +10% 50 Hz ±5% 60 Hz ±5%

Motor Power rating on motor plate (1)		Mains				Altivar 68						References (7)
		Line current (2)				Maximum rated current				Maximum transient current (4)	Power dissipated at rated load (5)	
500 V 440 V 400 V	460 V	400 V	440 V	460 V (6)	500 V	400 V	440 V	460 V (6)	500 V			
kW	HP	A	A	A	A	A	A	A	A	A	W	
90	100	159	145	116	128	170	155	124	136	213	2400	ATV-68C10N4
110	125	193	175	146	155	206	187	156	165	258	2800	ATV-68C13N4
132	150	234	212	169	188	250	227	180	200	312	3250	ATV-68C15N4
160	200	280	269	225	226	300	288	240	240	375	3800	ATV-68C19N4
200	250	365	338	283	293	390	362	302	312	488	4700	ATV-68C23N4
250	300	453	411	338	365	485	440	361	388	606	5800	ATV-68C28N4
315	350	533	483	388	429	570	517	414	456	713	7300	ATV-68C33N4
400	500	692	662	553	556	740	708	590	592	926	9100	ATV-68C43N4
500	600	860	808	675	692	920	864	720	736	1151	11300	ATV-68C53N4
630	800	1015	942	787	816	1085	1008	840	868	1356	14000	ATV-68C63N4

- (1) Power values given for a switching frequency of 2.5 kHz in steady state. For switching frequencies of 5 and 10 kHz, refer to table on page 7.
- (2) Typical current values, given with additional line choke for rated voltage and for maximum rated current. 400 V... 500V, the presumed short circuit current is 22000 A.
- (3) Transient current for 60 seconds every 10 minutes for voltage 400 V (corresponding to 1.5 times the maximum rated current).
- (4) Transient current for 60 seconds every 10 minutes for voltage 400 V (corresponding to 1.2 times the maximum rated current).
- (5) Power dissipated at maximum rated current and switching frequency of 2.5 kHz.
- (6) In 460 V, only high torque is available.
- (7) Characteristics identical for the ATV-66FC●●N4.

# Available torque

## Continuous operation

For self-cooled motors, cooling is linked to motor speed. Derating therefore occurs at speeds less than the rated speed. Before adjustment of the integrated thermal protection, it is advisable to consult the motor thermal constant values issued by the motor manufacturer.

## Transient operation

The overtorque depends on the maximum transient current of the speed controller. At startup, the maximum limiting torque is programmable as a function of the speed to up to 1.8 times rated torque.

## Overspeed operation

Above rated motor speed, voltage being unable to increase with frequency, there is a reduction in motor induction which results in torque loss. Warning: consult the motor manufacturer on the mechanical consequences of motor overspeed operation.

## High torque applications: torque characteristics

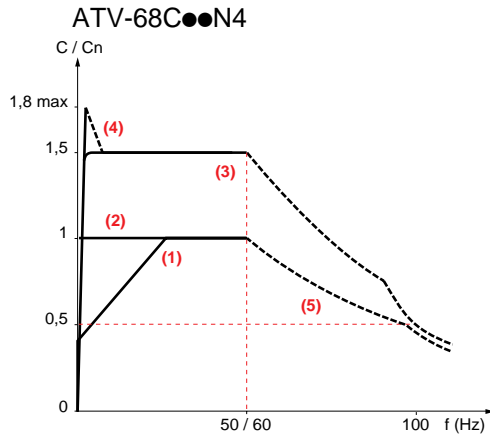

- (1) Self-cooled motor = steady usable torque (adjustable internal protection).
- (2) Force-cooled motor = permanent usable torque.
- (3) Overtorque available for 60 seconds maximum.
- (4) Starting overtorque possible.
- (5) Overspeed torque at more or less constant power.

- Note (1) (2) (3): the time depends on the dimensioning and thermal capacity of the speed controller.

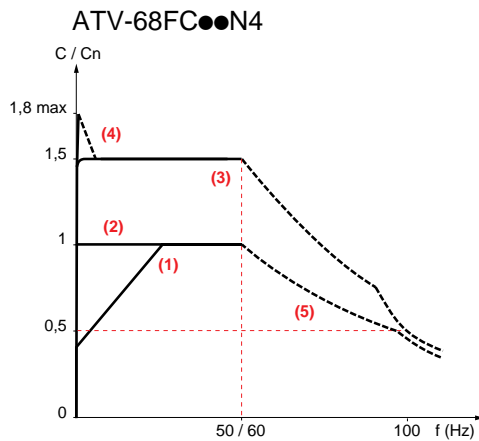

## Standard torque applications (variable torque): torque characteristics

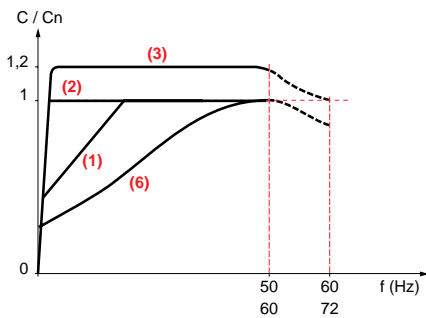

- (1) Self-cooled motor = permanent usable torque (adjustable internal protection).
- (2) Force-cooled motor = permanent usable torque.
- (3) Overtorque available for 60 seconds maximum.
- (6) Typical permanent usable torque in variable torque operation.

# Technical characteristics

## Environment

<b>Conformity to standards</b>	<ul style="list-style-type: none"> <li>- speed controller designed, constructed and tested conforming to EN 50178,</li> <li>- galvanic isolation conforming to EN 50178, PELV,</li> <li>- EMC immunity conforming to IEC 61800-3 (IEC 1000-4-2, IEC 1000-4-3, IEC 1000-4-4, IEC 1000-4-5),</li> <li>- EMC: transmission conforming to IEC 61800-3 (environment 2)</li> </ul> <p>High frequency transmission, optional suppression filters for industrial environments</p>																																																										
<b>CE marking</b>	<ul style="list-style-type: none"> <li>- speed controller designed conforming to European Directives:</li> </ul> <p>Low Voltage Directive 73 / 23 EEC and EMC Directive 89/336 for industrial environments</p>																																																										
<b>Approval</b>	<p>UL "OPEN DEVICE"</p> <p>To ensure UL conditions, the symetrical short circuit current of the inverter mains supply may not exceed the values listed below :</p> <ul style="list-style-type: none"> <li>- ATV-68C10N4 - C19N4 = 10 000 A,</li> <li>- ATV-68C23N4 - C33N4 = 18 000 A,</li> <li>- ATV-68C43N4 - C63N4 = 30 000 A.</li> </ul>																																																										
<b>Degree of protection</b>	IP00 with front panel protection (requires protection against direct contact by personnel)																																																										
<b>Ambient air temperature Derating as a function of switching frequency</b>	<ul style="list-style-type: none"> <li>- the speed controller - motor association table is based on a switching frequency of 2.5 kHz and an ambient temperature of 40°C (or 45°C depending on rating). Operation is possible at an ambient temperatures 10°C higher than the maximum ambient temperature indicated below. In this case, it is necessary to derate the speed controller current by an additional 2% per °C.</li> <li>- operation is also possible with switching frequency higher than 2.5 kHz applying the following derating:</li> </ul> <table border="1" style="width: 100%; border-collapse: collapse; text-align: center;"> <thead> <tr> <th></th> <th>Max. ambient temperature</th> <th>2.5 kHz</th> <th>5 kHz</th> <th>10 kHz</th> </tr> </thead> <tbody> <tr> <td>ATV-68C10N4</td> <td>40°C</td> <td>In speed controller</td> <td>0.80 In speed controller</td> <td>0.45 In speed controller</td> </tr> <tr> <td>ATV-68C13N4</td> <td>45°C</td> <td>In speed controller</td> <td>0.95 In speed controller</td> <td>0.78 In speed controller</td> </tr> <tr> <td>ATV-68C15N4</td> <td>45°C</td> <td>In speed controller</td> <td>0.85 In speed controller</td> <td>0.58 In speed controller</td> </tr> <tr> <td>ATV-68C19N4</td> <td>40°C</td> <td>In speed controller</td> <td>0.80 In speed controller</td> <td>0.52 In speed controller</td> </tr> <tr> <td>ATV-68C23N4</td> <td>45°C</td> <td>In speed controller</td> <td>1.00 In speed controller</td> <td>0.80 In speed controller</td> </tr> <tr> <td>ATV-68C28N4</td> <td>45°C</td> <td>In speed controller</td> <td>0.86 In speed controller</td> <td>0.64 In speed controller</td> </tr> <tr> <td>ATV-68C33N4</td> <td>40°C</td> <td>In speed controller</td> <td>0.82 In speed controller</td> <td>0.60 In speed controller</td> </tr> <tr> <td>ATV-68C43N4</td> <td>45°C</td> <td>In speed controller</td> <td>1.00 In speed controller</td> <td>0.80 In speed controller</td> </tr> <tr> <td>ATV-68C53N4</td> <td>45°C</td> <td>In speed controller</td> <td>0.86 In speed controller</td> <td>0.64 In speed controller</td> </tr> <tr> <td>ATV-68C63N4</td> <td>40°C</td> <td>In speed controller</td> <td>0.82 In speed controller</td> <td>0.60 In speed controller</td> </tr> </tbody> </table> <ul style="list-style-type: none"> <li>- Comply with UL conditions, the maximum ambient temperature of all speed controllers is 40°C,</li> <li>- for installation in an enclosure, consult the chapter "Enclosure installation"</li> <li>- for storage: - 25°C ... + 70°C.</li> </ul>					Max. ambient temperature	2.5 kHz	5 kHz	10 kHz	ATV-68C10N4	40°C	In speed controller	0.80 In speed controller	0.45 In speed controller	ATV-68C13N4	45°C	In speed controller	0.95 In speed controller	0.78 In speed controller	ATV-68C15N4	45°C	In speed controller	0.85 In speed controller	0.58 In speed controller	ATV-68C19N4	40°C	In speed controller	0.80 In speed controller	0.52 In speed controller	ATV-68C23N4	45°C	In speed controller	1.00 In speed controller	0.80 In speed controller	ATV-68C28N4	45°C	In speed controller	0.86 In speed controller	0.64 In speed controller	ATV-68C33N4	40°C	In speed controller	0.82 In speed controller	0.60 In speed controller	ATV-68C43N4	45°C	In speed controller	1.00 In speed controller	0.80 In speed controller	ATV-68C53N4	45°C	In speed controller	0.86 In speed controller	0.64 In speed controller	ATV-68C63N4	40°C	In speed controller	0.82 In speed controller	0.60 In speed controller
	Max. ambient temperature	2.5 kHz	5 kHz	10 kHz																																																							
ATV-68C10N4	40°C	In speed controller	0.80 In speed controller	0.45 In speed controller																																																							
ATV-68C13N4	45°C	In speed controller	0.95 In speed controller	0.78 In speed controller																																																							
ATV-68C15N4	45°C	In speed controller	0.85 In speed controller	0.58 In speed controller																																																							
ATV-68C19N4	40°C	In speed controller	0.80 In speed controller	0.52 In speed controller																																																							
ATV-68C23N4	45°C	In speed controller	1.00 In speed controller	0.80 In speed controller																																																							
ATV-68C28N4	45°C	In speed controller	0.86 In speed controller	0.64 In speed controller																																																							
ATV-68C33N4	40°C	In speed controller	0.82 In speed controller	0.60 In speed controller																																																							
ATV-68C43N4	45°C	In speed controller	1.00 In speed controller	0.80 In speed controller																																																							
ATV-68C53N4	45°C	In speed controller	0.86 In speed controller	0.64 In speed controller																																																							
ATV-68C63N4	40°C	In speed controller	0.82 In speed controller	0.60 In speed controller																																																							
<b>Maximum relative humidity</b>	95% without condensation or dripping water.																																																										
<b>Environment class</b>	class 3K3 conforming to IEC 721-3-3.																																																										
<b>Maximum ambient pollution</b>	degree 2 conforming to IEC 664-1 and EN50178																																																										
<b>Maximum operating altitude</b>	1000 m without derating (above this derate the power by 1 % for each additional 100 m up to 2000 m)																																																										
<b>Operating position</b>	Vertical																																																										
<b>Noise level of speed controller</b>	ATV-68C10N4 to C19N4 65 dB (A)	ATV-68C23N4 to C33N4 72 dB (A)	ATV-68C43N4 to C63N4 74 dB (A)																																																								

# Technical characteristics

## Electrical characteristics

<b>Protection and safety features of speed controller</b>	<ul style="list-style-type: none"> <li>- Short-circuit protection: between output phases between output phases and earth (except in IT operating conditions) on available internal supply outputs</li> <li>- Thermal protection against overheating and overcurrent.</li> <li>- Protection against supply overvoltage and undervoltage.</li> </ul>
<b>Motor protection</b>	<ul style="list-style-type: none"> <li>- Thermal protection integrated in speed controller using continuous calculation of I<sup>2</sup>t taking speed into account</li> <li>- Memorization of motor thermal state when the speed controller is connected to an external 24 V supply</li> <li>- Function can be modified (using programming terminal, depending on the type of motor cooling used and the motor thermal characteristics)</li> <li>- Protection with integrated PTC probes</li> </ul>
<b>Power supply</b>	<ul style="list-style-type: none"> <li>- 400 V ± 15% three-phase 50/60 Hz ± 5%</li> <li>- 440 V ± 10% three-phase 60 Hz ± 5%</li> <li>- 460 V - 10% to 480 + 10% three-phase 60 Hz ± 5%</li> <li>- 500 V - 15%, + 10% three-phase 50 Hz ± 5%</li> </ul>
<b>Maximum output voltage</b>	Equal to line supply voltage.
<b>Isolation</b>	Galvanic isolation conforming to EN 50 178 between control and power PELV: inputs, outputs, supplies.
<b>Output frequency</b>	from 0 to 50 / 60 Hz, extension up to 300 Hz, frequency stability: ± 0.01% at 50 Hz.
<b>Maximum transient current</b>	<ul style="list-style-type: none"> <li>- 400 V, 440 V and 500 V, 150% of rated current in high torque operation for 60 sec then 120% permanent, 120% of rated current in standard torque operation (variable torque) for 60 sec then 100% permanent.</li> <li>- With 460 V, 150% of rated current for 60 sec, then 100% permanent.</li> </ul> <p>Current limitation depends on heat sink temperature. In the case of use of the speed controller beyond its thermal capacity, the speed controller automatically reduces the switching frequency and if necessary the transient limitation current.</p>
<b>Starting overtorque</b>	Up to 180% of rated torque at low speed for high torque applications.
<b>Speed controller efficiency</b>	97.7% at 50 Hz at rated load (including line inductance).



# Dimensions and fixing

## ATV-68C10N4

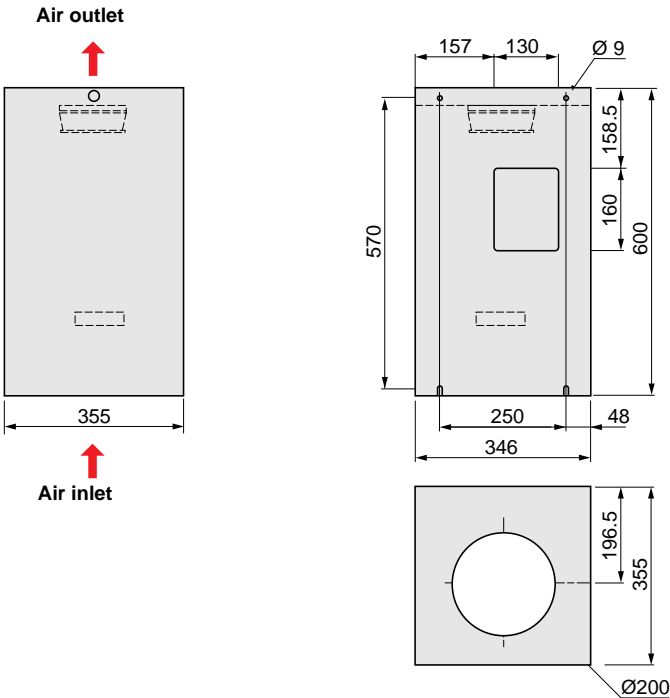

Weight: 60 kg  
 Fan air flow: 450 m<sup>3</sup> / hr  
 Air inlet/outlet: minimum circulation area 6 dm<sup>2</sup> excluding filter

## ATV-68C13N4 ATV-68C15N4 ATV-68C19N4

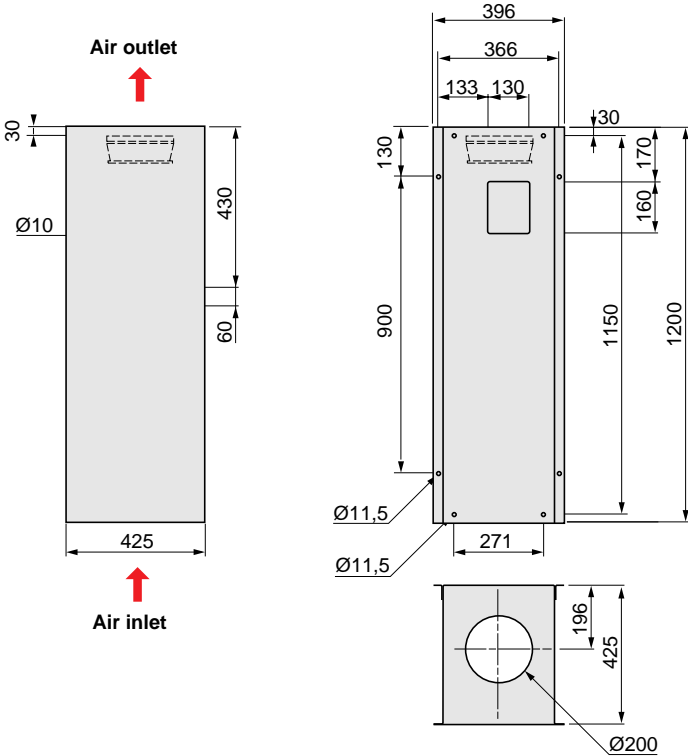

Weight: 100 kg  
 fan air flow: 600 m<sup>3</sup> / hr  
 air inlet/outlet: minimum circulation area 7 dm<sup>2</sup> excluding filter

# Dimensions and fixings

## ATV-68C23N4 to 68C33N4

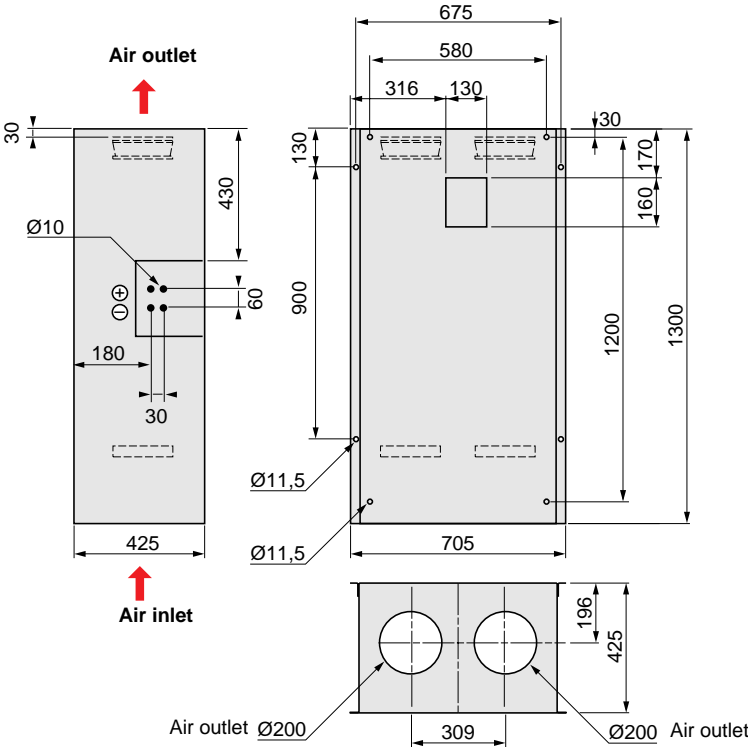

Weight: 190 kg  
 fan air flow: 1200 m<sup>3</sup> / h  
 air inlet/outlet: minimum circulation area 10 dm<sup>2</sup> excluding filter

## ATV-68C43N4 to 68C63N4

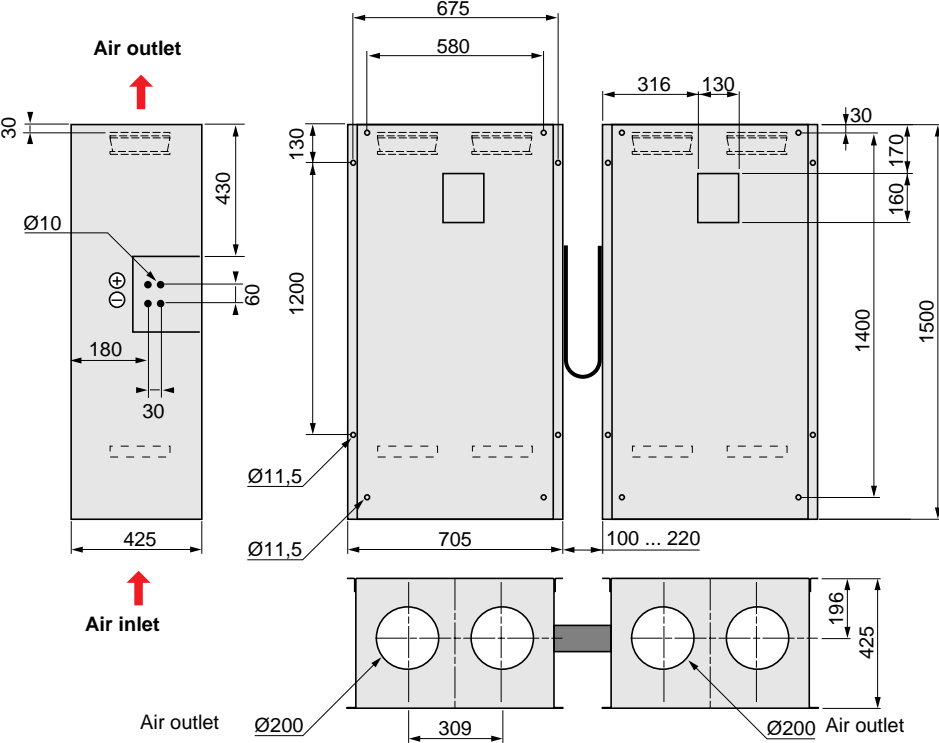

Weight: 500 kg (2 x 250 kg)  
 fan air flow: 2400 m<sup>3</sup> / h  
 air inlet/outlet: minimum circulation area 20 dm<sup>2</sup> excluding filter

# Mounting recommendations

## General

Ensure that the input voltage (3-phase a.c.) is:

- 400 V  $\pm$  15% three-phase 50 Hz  $\pm$  5% / 60 Hz  $\pm$  5%,
- 440 V  $\pm$  10% three-phase 60 Hz  $\pm$  5%,
- 460 V - 10% to 480 + 10% three-phase 60 Hz  $\pm$  5%,
- 500 V - 15% three-phase 50 Hz  $\pm$  5%.

Avoid harmful environments, such as those with high temperature and humidity levels as well as environments containing dust, dirt or corrosive vapours and gas. The location must be well ventilated and away from direct sunlight.

Install the equipment against a vertical surface which is fireproof and vibration-free.

Warning! Do not apply line voltage to output terminals U, V, W which are the motor supply terminals. Line supply voltage terminals are L1, L2, L3.

Please consult the motor manufacturer if the motor is to operate at more than 60 Hz.

The isolation resistance and dielectric strength of all speed controllers has been checked. In the case of periodic inspections, isolation measurements can be made between the power terminals and earth but under no circumstances to the control terminals.

START / STOP is by the control terminals or the keypad, not by closing a contactor on the supply or output to the motor. The equipment is designed to be energized approximately 60 times per hour.

Do not install capacitors or overvoltage protection devices on the motor cables.

## Distances from other equipment and surfaces

To ensure convection cooling, Altivar 68 speed controllers are designed for vertical installation. Observe the minimum recommended clearances, especially if the equipment is enclosed.

The ingress of objects during installation risks causing damage to the equipment: ensure that no objects, wires, wire insulation, swarf or dust enter the equipment by covering it when it is not connected to the supply.

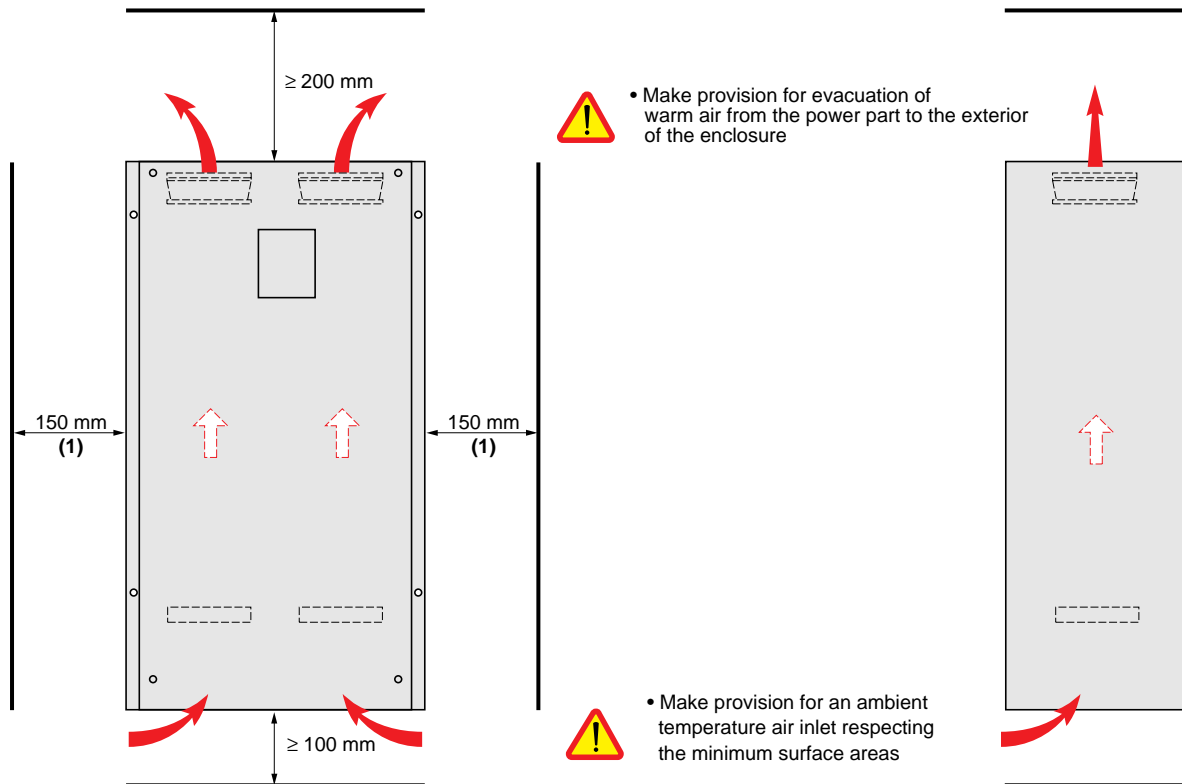

(1) Clearances at the sides are only required for access during maintenance. If the equipment can be easily removed, these clearances are not necessary.

## Recommendations

Maximum ambient temperatures must not be exceeded (see tables on page 7). If the maximum temperature of the heatsink is reached, the switching frequency of the speed controller is automatically reduced and if this is not sufficient, the maximum current limitation value is also reduced. If the ambient temperature is higher, the service life of the inverter is reduced. Never install the equipment near a heat source.

If the equipment is to be installed in an enclosure, take into account the enclosure dimensions and its heat dissipation capabilities. If necessary, install an auxiliary forced ventilation system.

### ATV-68C10N4

**Degree of protection IP20-IP23, with maximum ambient temperature of 40 °C outside the enclosure.**

Air flow: 450 m<sup>3</sup>/H

- Aperture to avoid circulation of air from power part in the enclosure.
- Free part to facilitate circulation of air.
- Air inlet (without filter) of 6 dm<sup>3</sup>.
- Fan

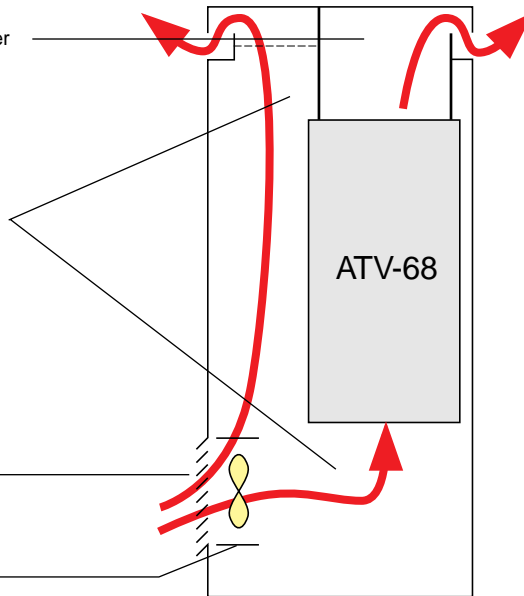

### ATV-68C13N4 to C63N4

The power block is accessed by tilting it forward, as shown in the drawing below. For maintenance, provide a free space of 1.20 metres at the front.

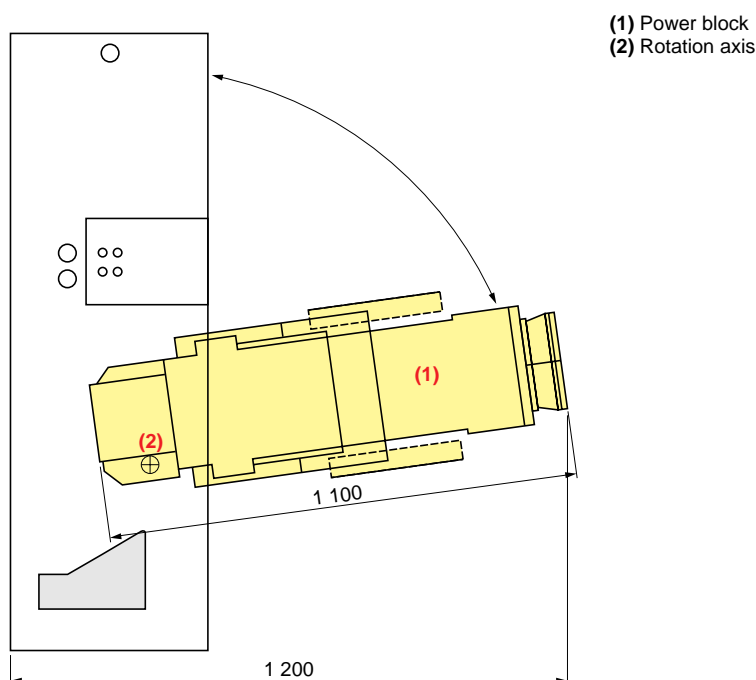

# ATV-68 enclosure mounting

## ATV-68 C13N4 to C63N4

Degree of protection IP20 - IP23, with maximum ambient temperature of +35/+40°C\* outside the enclosure

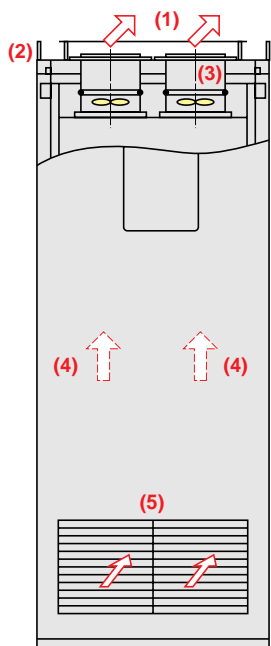

(1) The grille in the upper part must be spaced from the roof of the enclosure by at least 60 mm and should guarantee air circulation on all four sides.

(2) Mounting of separation partitions is essential if the fans of adjacent enclosures create back pressure.

Circulation of air within the enclosure must not be obstructed by the presence of additional components\* (line chokes, motor filters,...) mounted between enclosure air inlet and speed controller ventilation inlet in the upper part, and between speed controller and enclosure air outlets in the lower part. No source of heat should be mounted under the speed controller!

\* excepting radio frequency suppression input filters and wiring

(3) Air output ducts (VW3A68 801): 1, 2 or 4 air outlets depending on the rating, fitted in the upper part of the enclosure (internal diameter 195 mm supplied with rubber seal).

- Air circulation around the ventilation outlet should be 10 m/sec (approximately 35 km/hr) so that each air duct creates an increase in pressure.

- Air flow / rating

Air flow in m <sup>3</sup> / hr	ATV68 rating
600	C13N4 to C19N4
2 x 600	C23N4 to C33N4
4 x 600	C43N4 to C68N4

(4) If another enclosure is mounted immediately adjacent to the speed controller enclosure, the separation partition must be used to avoid heat exchange.

(5) Air inlet. Do not install a filter and respect the minimum areas below.

Area dm <sup>3</sup>	ATV68 rating
7	C13N4 to C19N4
10	C23N4 to C33N4
20	C43N4 to C68N4

example ATV-68C33N4

\* to obtain the maximum ambient temperature: see table page 7 and reduce by 5°C to take into account temperature rise due to enclosure mounting.

Degree of protection IP20 - IP23, with maximum ambient temperature of +40/+45°C\*\* outside the enclosure

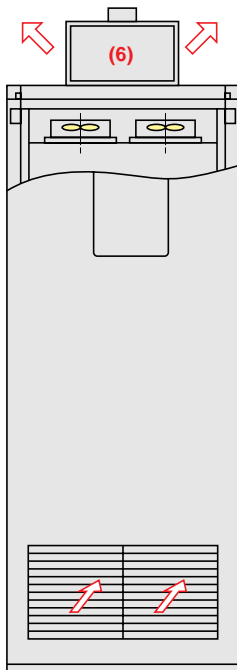

This option avoids speed controller derating where the ambient air temperature outside the enclosure of +40 / +45°C (see table page 7).

(6) Additional fan.  
Fan kit option **VW3A68820**.  
Volume processed >1500 m<sup>3</sup>/h.  
The cooling air flowing through the enclosure fans is evacuated by the additional fan. Air duct(s) should not be used.

example: ATV-68C33N4

\*\* See table page 7.

**Note**

To obtain an IP54 degree of protection, please consult the Schneider sales offices.

# Access to terminals

## ATV-68C10N4

To access the power and control terminals, remove the front panel.



Ensure the voltage has disappeared before removing the panel. Voltage on terminals + and - should be less than 60 V DC.

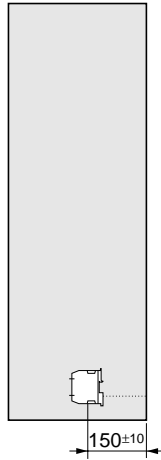
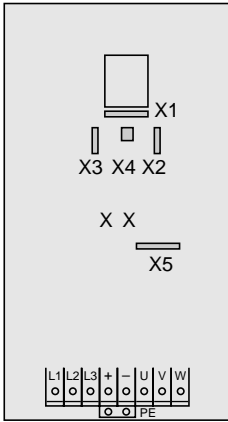

Terminals	Function
L1, L2, L3	Line connection
U, V, W	Motor connection
Line PE	Earth connection
Motor PE	Earth connection
+, -	DC Bus

### Location of terminals

X1: control terminals on control card  
 X2: terminals on input/output option card  
 X3: terminals on second input/output option card  
 X4: RS232 connection (connection to PC)  
 X5: encoder feedback card connections  
 X X: terminals for control cable shielding

### Power terminal

Tightening torque:  
 - 10 Nm (88 Lb.in.) for Mains, Motor, +/-,  
 - 20 Nm (177 Lb.in.) for PE (bolt M8 Ø 9).

## ATV-68C13N4 ATV-68C15N4 ATV-68C19N4

To access the power and control terminals, remove the front panel.



Ensure the voltage has disappeared before removing the panel. Voltage on terminals + and - should be less than 60 V DC.

For the braking unit, use the DC bus connection kit VW3 A68 802.

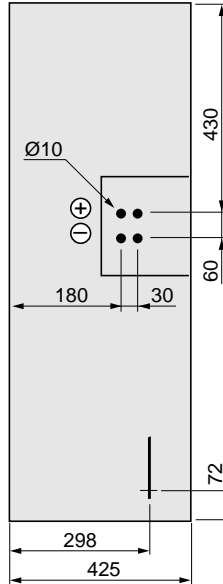
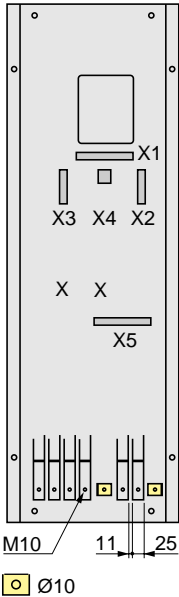

Terminals	Function
L1, L2, L3	Line connection
U, V, W	Motor connection
Line PE	Earth connection
Motor PE	Earth connection
+, -	DC Bus

### Location of terminals

X1: control terminals on control card  
 X2: terminals on input/output option card  
 X3: terminals on second input/output option card  
 X4: RS232 connection (connection to PC)  
 X5: encoder feedback card connections  
 X X: terminals for control cable shielding

### Power connections

Tightening torque: 40 Nm (355 Lb.in.)



For the braking unit, use the DC bus connection kit VW3 A68 802.

# Access to terminals

## ATV-68C23N4 to ATV-68C33N4

To access power and control terminals, remove the front panel.



Ensure the voltage has disappeared before removing the panel. Voltage on terminals + and - should be less than 60 V DC. For the braking unit, use the DC bus connection kit VW3 A68 802.

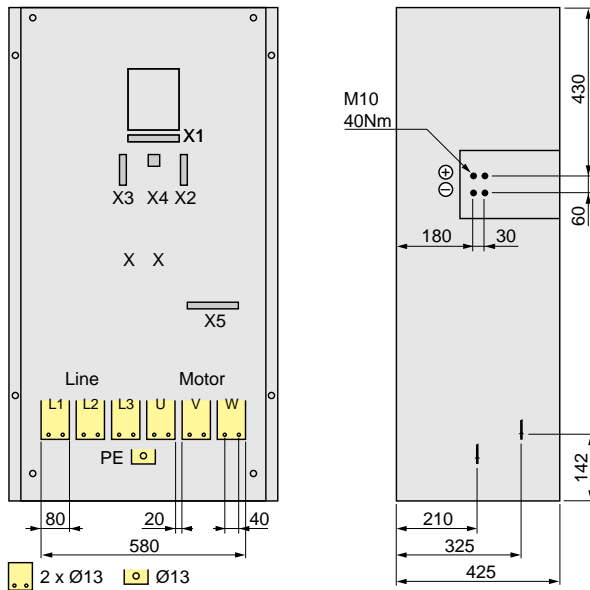

Terminals	Function
L1, L2, L3	Line connection
U, V, W	Motor connection
Line PE	Earth connection
Motor PE	Earth connection
+, -	DC Bus

### Location of terminals

X1: control terminals on control card  
 X2: terminals on input/output option card  
 X3: terminals on second input/output option card  
 X4: RS232 connection (connection to PC)  
 X5: encoder feedback card connections  
 X X: terminals for control cable shielding

### Power connections

Tightening torque: 70 Nm (620 Lb.in.)

## ATV-68C43N4 to ATV-68C63N4

To access power and control terminals, remove the front panel.



Ensure the voltage has disappeared before removing the panel. Voltage on terminals + and - should be less than 60 V DC. For the braking unit, use the DC bus connection kit VW3 A68 802.

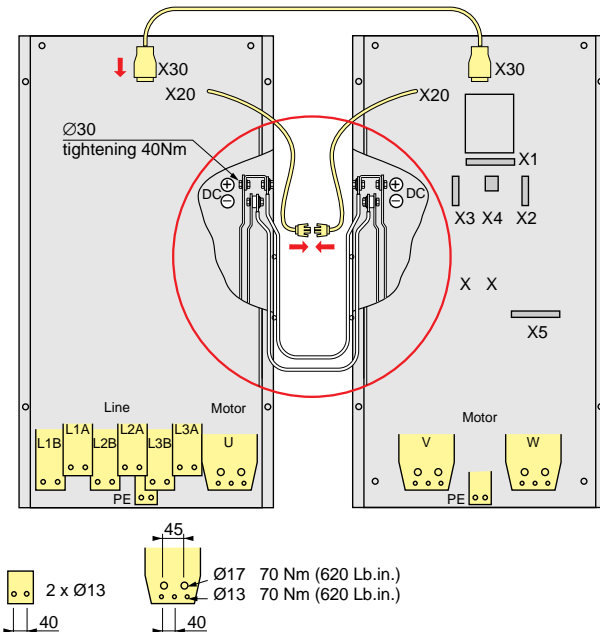

### Location of terminals

X1: control terminals on control card  
 X2: terminals on input/output option card  
 X3: terminals on second input/output option card  
 X4: RS232 connection (connection to PC)  
 X5: encoder feedback card connections  
 X X: terminals for control cable shielding

### Power connections

Tightening torque: 70 Nm (620 Lb.in.)

The two modules are delivered separately and not interconnected. The three following connections are necessary:

- +/- DC bus
- X20
- X30

- Connect the +/- DC buses of the two modules using the two flexible busbars supplied with the modules,
- Interconnect the two x20 connectors of each module (the x20 cable is supplied rolled around the +/- DC bus terminals of each module),
- Connect the x30 connector to the left-hand module, passing the cable above the module between the two cooling fans to the electronic card (this cable is supplied rolled around the cooling fans of the right-hand module containing the graphic terminal).

Terminals	Function
L1A - L1B	Phase L1 line connection
L2A - L2B	Phase L2 line connection
L3A - L3B	Phase L3 line connection
X20	Connection cable for phase U voltage measurement (1 wire)
X30	Control module interconnection cable
U, V, W	Motor connection
Line PE	Earth connection
Motor PE	Earth connection
+, -	DC Bus

# Wiring diagrams for control terminals

## Installation and wiring instructions for connecting the control part:

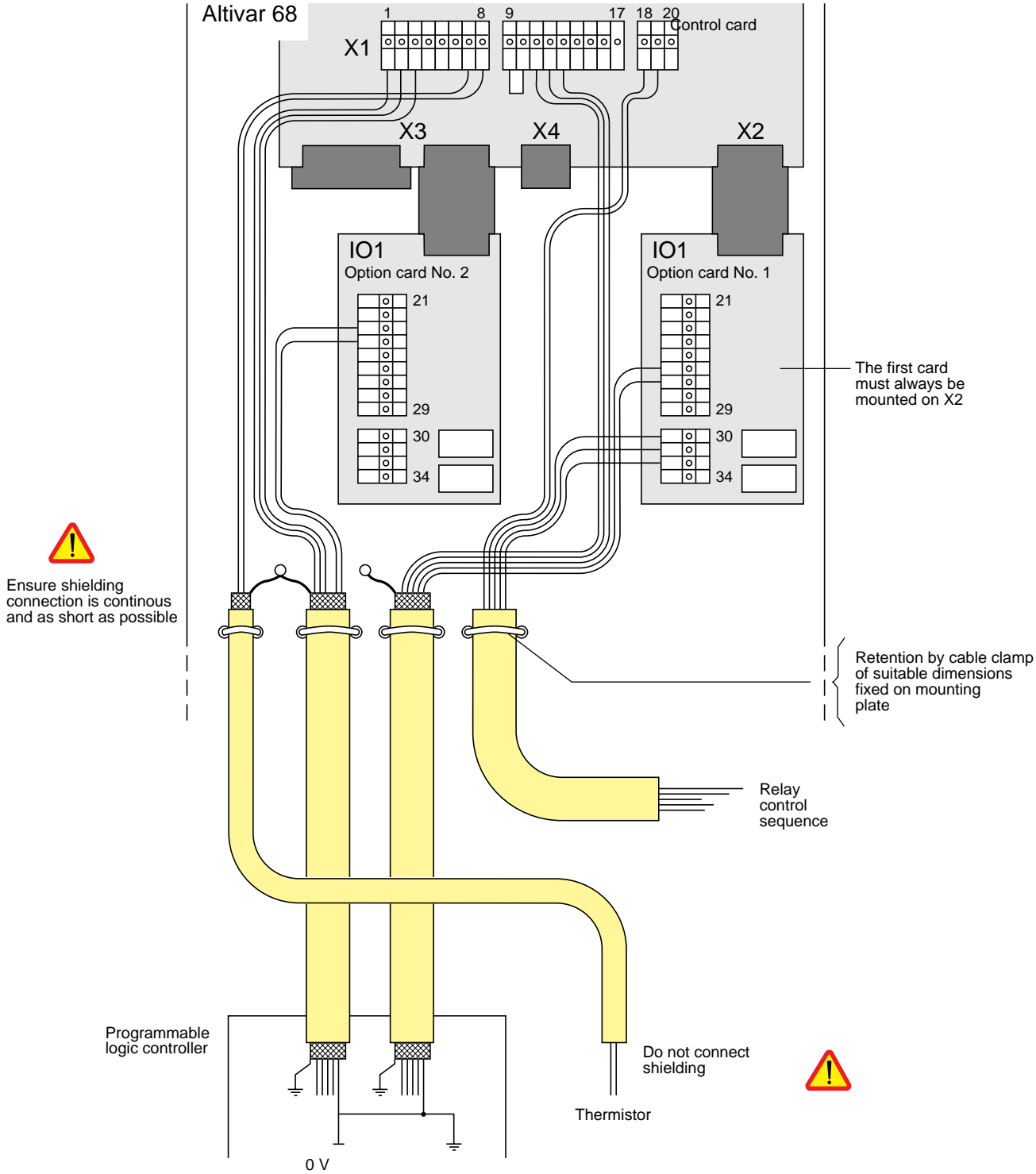



# Wiring diagrams for control terminals

## Control card technical specifications

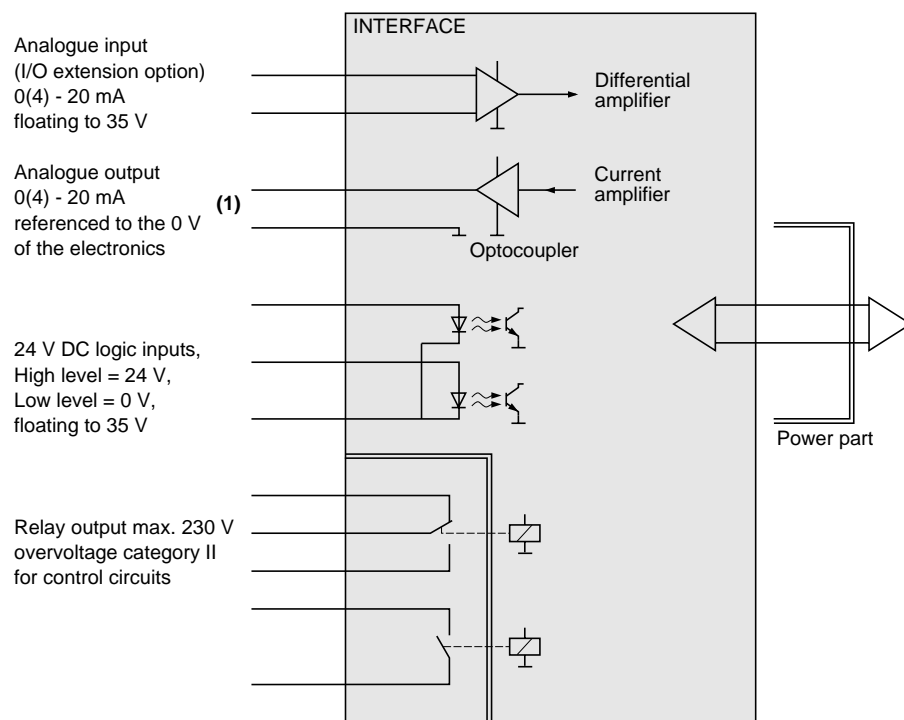

By desing the control inputs and outputs are isolated from the mains supply. To maintain safety conditions, it is necessary to limit direct voltages to less than 60 V DC with respect to earth. This is ensured if electrical zero is always at a voltage of less than 35 V with respect to earth potential.

The inputs and outputs are not coupled to each other (when using analogue inputs and an external 24 V power supply for logic inputs).

Control card and inputs/outputs option card potentials are galvanically double insulated conforming to EN 50178 (PELV).

**Warning:** The supplies of relay contacts should be of overvoltage category II maximum to conserve PELV conformity on the other terminals.

It is also recommended that the power supplies of the relay contacts with respect to line be galvanically insulated.

To obtain PELV conformity on the contacts of the input/output extension card relays, the contact supplies of the two relays should be in 24 V and be double insulated with respect to line (or with reinforced insulation).

To ensure UL conditions for use with coils according to D300 (UL 508, table 127.1) only.

# Wiring diagrams for control terminals

## Connection of X1 control card terminal block

The control cables must be kept separate from supply, motor and other cabling. They must not be more than 20 m long and must be twisted and shielded.

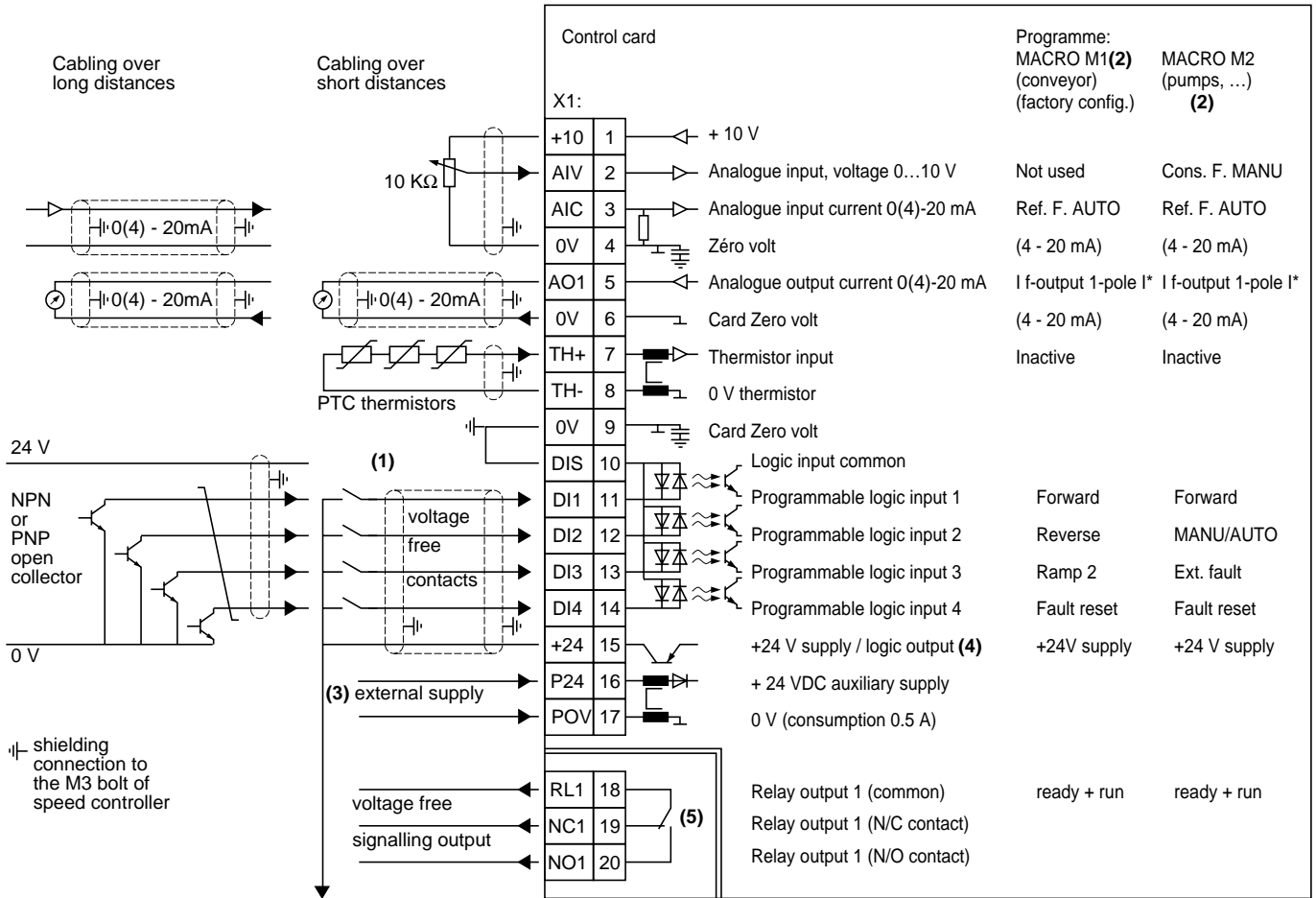

The control terminals are totally isolated from earth.

- (1) To ensure that personnel are protected in the event of direct contact, the zero voltage of the electronics card must not exceed 35 V in relation to earth. If necessary, connect this to the inverter earth or the PLC analog output earth. The speed controller electrical zero volt is floating and connected to earth via an HF filtering capacitor to eliminate interference.
- (2) For other macro-programs, please consult the programming manual.
- (3) An external 24 V power supply can be used to maintain the control supply to the speed controller for adjustments and overload memory in the event of a loss of power.
- (4) X1-15 can be used for +24 V supply of logic inputs. By programming, X1-15 can be converted to logic output.
- (5) For relay contacts power supply conditions, see "Control card technical specifications".

\* Absolute value.

# Wiring diagrams for X2 and X3 input/output extension card terminals

If line supply and/or motor cables must cross the control cables, ensure they cross at right-angles.

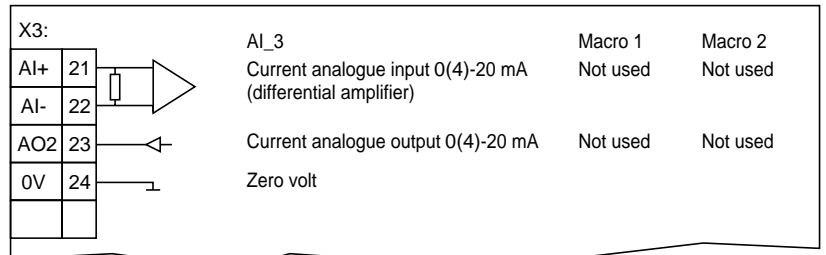
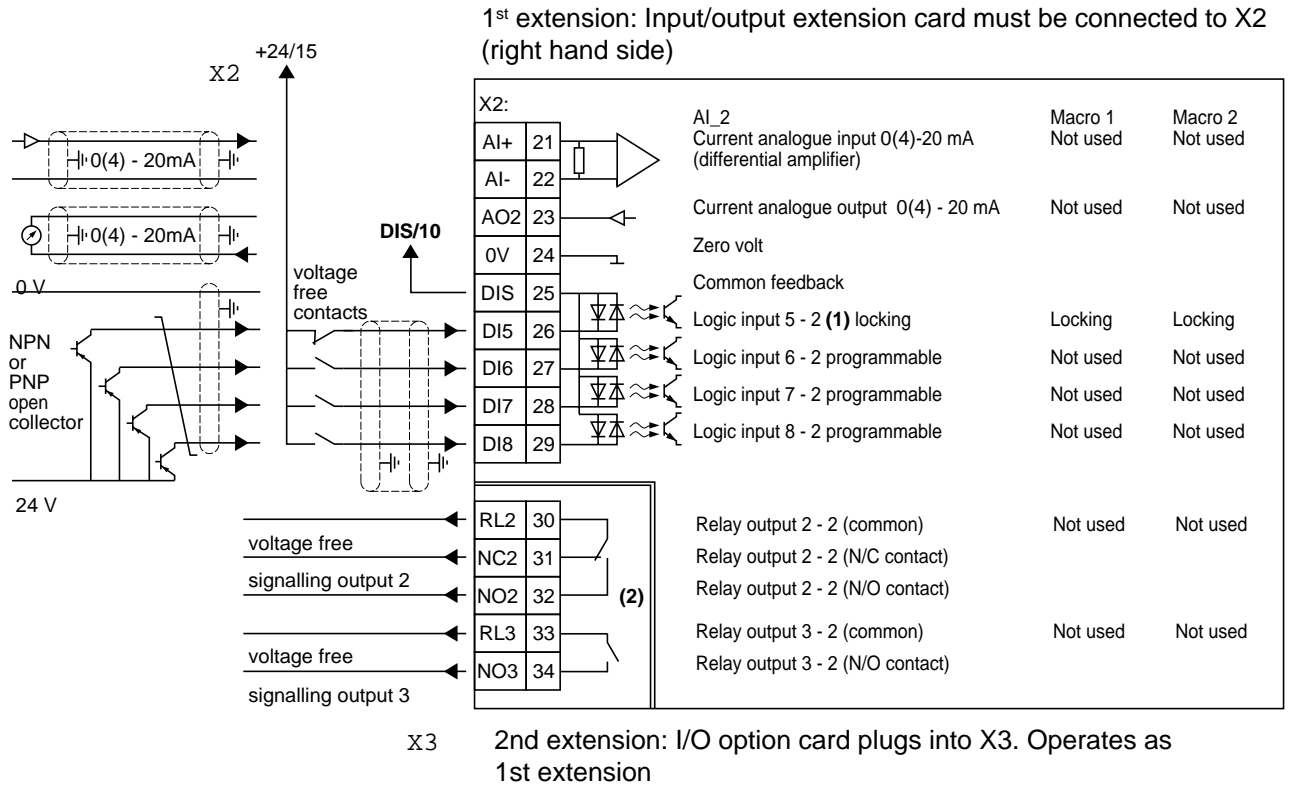

**Warning:**

- Connection of the I/O extension option to X2 assigns the "locking" function to the logic input DI5 and requires a level 1 so that the speed controller can function (necessary for Auto-Tuning) for example with a connection of 0 V (X1: 9)- DIS (X1: 10) DIS (X2: 25) and + 24 (X1: 15) - DI5 (X2: 26).

**Note:** It is possible to connect 2 input/output cards simultaneously. The first card should be connected to X2.

- For relay contacts power supply conditions, see "Control card technical specifications".

# Wiring diagrams: encoder feedback and RS232 link card terminals

## Encoder feedback card connection

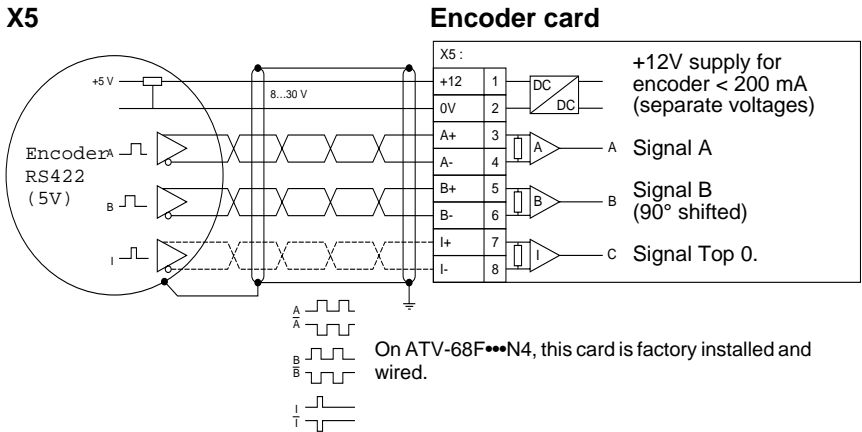

## Sub D 9 pin connector (Connection to PC)

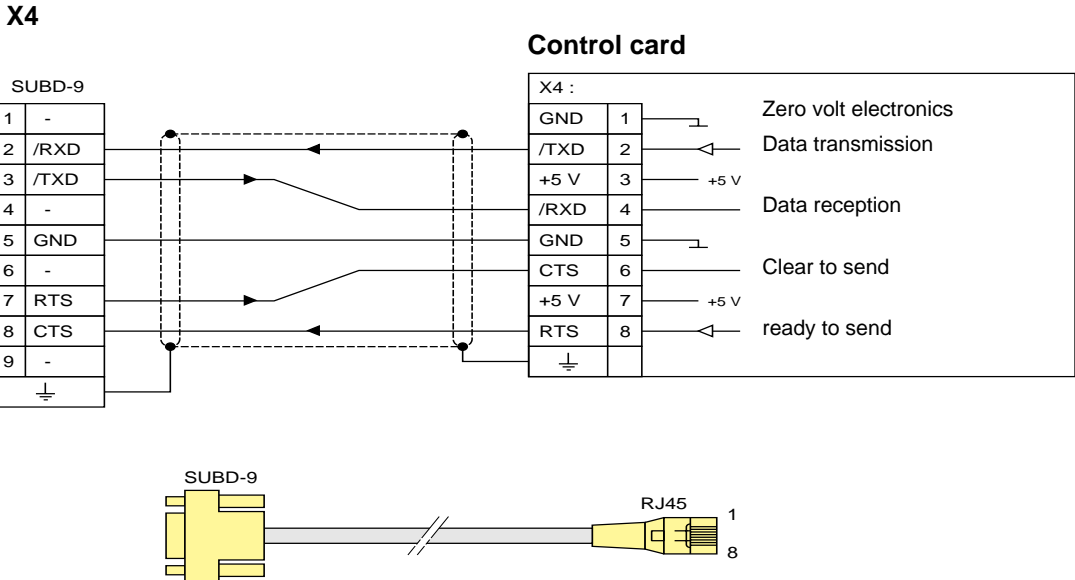

Cable reference for connection to personal computer: VW3A68332.

# Control terminal block characteristics

## Control card (UI 1) - X1 terminal block

Code	Terminal block	Terminal	Description	Characteristics
+10	X1	1	+10V internal supply	+10 V, +2% -0% at 0 - 10 mA; short-circuit protected.
AIV	X1	2	Analogue input AIV	0...10 V, impedance approx.: 100 k $\Omega$ , accuracy $\pm$ 0.6% of full scale (10 V), linearity deviation < - 0.15% with 1 k $\Omega$ at speed reference potentiometer, resolution 10 bits (~ 10 mV), limits and operation chosen using parameters
AIC	X1	3	Analogue input AIC	0(4) - 20 mA, load 250 $\Omega$ , accuracy $\pm$ 0.9% of full scale (20 mA), resolution 10 bits (~ 20 $\mu$ A), stability $\pm$ 0.2% of full scale / 50 Hz and temperature changing of 10 K, loss detection "4 mA" at 3 mA, limits and operation chosen using parameters
0 V	X1	4	0V	Zero volt <b>(1)</b>
AO1	X1	5	Analogue output A01	0(4) - 20 mA, max. load 600 $\Omega$ , resolution 10 bits, frequency accuracy, current, voltage = $\pm$ 1.5%; Torque, speed, power $\pm$ 5% 0 or 4 mA, limits and operation chosen using parameters
0 V	X1	6	0V	Zero volt <b>(1)</b>
TH+	X1	7	+ therm. probe input	For a maximum of 6 thermistors wired in series, cabling must be shielded and separate from the motor cable !! Thermistor rated value < 1.5 k $\Omega$ , tripping resistor 3 k $\Omega$ , reset value 1.8 k $\Omega$ , short-circuit protection below 50 $\Omega$ , measured current approx. 1 mA
TH-	X1	8	- therm. probe input	
0 V	X1	9	0V	Zero volt <b>(1)</b>
DIS	X1	10	Common	Common terminal for all control card logic inputs, may float on a maximum range of 35 V between earth and zero volt.
DI1	X1	11	Logic input DI1	Optocoupler input for 24 V, min. on energisation time: 10 ms, bipolar, for both positive and negative logic, approx. 8 mA at 24 V, limits and operation chosen using parameters. State 1 above 15 V, state 0 below 4 V.
DI2	X1	12	Logic input DI2	Same as X1 11
DI3	X1	13	Logic input DI3	Same as X1 11
DI4	X1	14	Logic input DI4	Same as X1 11
+24	X1	15	Logic output or +24V internal supply	Supply voltage 24 V, 150 mA max., may be used as an auxiliary constant voltage for logic inputs or as parametered data logic output. Tolerance: +25%, -15%
P24	X1	16	Input for +24V external supply	24 V external supply for the electronics in case of mains failure. Tolerance: +25%, -10% including residual ripple, approx. required current 0.5 A (without BUS), separated from the internal 24 V by diode.
P0V	X1	17	0V	
RL1	X1	18	Relay output 1 common	Switching voltage: 250 V AC or 30 V DC Switching power: 1250 VA max., 150 W Max. DC current: 3 A Min. switched current (new relay) 24 V DC, 3 mA For relay contacts power supply conditions, see "Control card technical specifications". To ensure UL conditions for use with coils according to D300 (UL 508, table 127.1) only.
NC1	X1	19	N/C contact	
NO1	X1	20	N/O contact	

**(1)** The 0 V for electronics may float up to 35 V with regard to PE.

# Control terminal block characteristics

## Input / output option card on X2 and X3 terminal blocks

X2: first I/O card terminal block, x3: second I/O card terminal block.

Code	Terminal block	Terminal	Description	Characteristics
AI+	X2 (X3)	21 22	Analogue current input AI2_2 (AI2_3)	0(4) - 20 mA, differential amplifier, floating up to $\pm 35$ V with regard to earth and 0 V, accuracy $\pm 1.1\%$ of full scale (20 mA) (up to 2% at 35 V), stability $\pm 0.2\%$ / 10 K, resolution 10 bits, load 250 $\Omega$ , protection on input from - 60 V to + 60 V, 3 mA Live/Zero supervision, limits and operation chosen by parameters.
AO2	X2 (X3)	23	Analogue current input AO2_2 (AO2_3)	Same as X1 terminal 5
0 V	X2 (X3)	24	0 V (0 V)	Zero volt <b>(1)</b>
DIS	X2 (X3)	25	Common (common)	Common of DI5 - DI8 logic inputs, if using voltage free contact, connect with the 0 V (Terminal block X1, terminal 9)
DI5	X2 (X3)	26	Logic input DI5_2 (DI5_3)	<b>Locking - unable to change</b> nor select. speed controller operation requires a signal at 1. ex: with connection to the +24 (terminal block X1 terminal 15) To the second card X3 logic input is programmable, same characteristics as terminal block X1 terminal 11)
DI6	X2 (X3)	27	Logic input DI6_2 (DI6_3)	Programmable, same characteristics as terminal block X1 terminal 11
DI7	X2 (X3)	28	Logic input DI7_2 (DI7_3)	Programmable, same characteristics as terminal block X1 terminal 11
DI8	X2 (X3)	29	Logic input DI8_2 (DI8_3)	Programmable, same characteristics as terminal block X1 terminal 11
RL2	X2 (X3)	30	Relay output 2_2 (relay output 2_3)	Same characteristics as terminal block X1 terminal 18 and terminal block X1 terminal 20
NC2	X2 and X3	31	N/C contact	For relay contacts power supply conditions, see "Control card technical specifications".
NO2	X2 and X3	32	N/O contact	
RL3	X2 (X3)	33	Relay output 3_2 (relay output 3_3)	For relay contacts power supply conditions, see "Control card technical specifications".
NO3	X2 and X3	34	N/O contact	

## Control card UI 1 - X4 connector - serial interface

Code	Terminal block	Terminal	Description	Characteristics
GND	X4	1	0 V	Zero volt <b>(1)</b>
/TXD	X4	2	Data transmission	Corresponds to RS 232 (rate: 9.6 or 19.2 kBaud)
+5V	X4	3	Supply	+5 V supply (4.75...5.25 V) Maximum charging current 50 mA
/RXD	X4	4	Data reception	Correspond to RS 232
GND	X4	5	0 V	Zero volt <b>(1)</b>
CTS	X4	6	Clear to send	Corresponds to RS 232
+5V	X4	7	Supply	+5 V supply (4.75...5.25 V) Maximum charging current 50 mA
RTS	X4	8	Ready to send	Corresponds to RS 232
PE	CASE		Earthing	Earthing point

**(1)** The Zero volt may float up to 35 V with regard to PE.

# Control terminal block characteristics

## Encoder feedback card

Code	Terminal block	Terminal	Description	Characteristics
+12	X5	1	Encoder supply	+12 V supply $\pm 7\%$ / maxi. 200 mA (including load)
0V	X5	2	0 V	Separation of the control electronics voltages <b>(1)</b>
A+	X5	3	Channel A	Signal corresponding to RS422, min. time $3\mu\text{s}$ for electrical $360^\circ$ and $180^\circ$ cyclic relation $\pm 10\%$ Maximum frequency 300 kHz, load $121\ \Omega$ with a 22 nF capacitance in series
A-	X5	4	Reverse Channel A	
B+	X5	5	Channel B	Signal B is $90^\circ$ shifted for rotational direction recognition
B-	X5	6	Reverse Channel B	
I+	X5	7	Top 0	Not required for the speed controller
I-	X5	8	Reverse Top 0	

**(1)** The Zero volt may float up to 35 V with regard to PE.

**Note:** The selected encoder, for example XCC-14/-15/ type or -19 type K, should have an input voltage range of 8 to 30 V (recommended). The encoder should be connected at a maximum distance of 100 m for 100 kHz (50 m for 300 kHz or 200 m for 50 kHz) using the AWG24 (0.2 mm<sup>2</sup>) cable.  
Type of cable: shielded TP (twisted pair)  
Output configuration: RS\_422\_5 V \_  
Output signals: A, A, B, B (I and I)  
Recommended resolution :  
- 2 pole motor : 30 to 2048 points per revolution  
- 4 pole motor : 60 to 4096 points per revolution  
- from 6 pole motor : 90 to 4096 points per revolution



**Warning:** "Speed feedback" option is supported from the PSR3.00 software version.  
To obtain an accurate range, there must be more than 200 increments per revolution.

Maximum frequency: 300 kHz.  
Maximum frequency =  $N_p \times F_s / p$ .  
 $N_p$  = max. number of points per encoder revolution  
 $F_s$  = Motor max. supply frequency  
 $p$  = number of pole pairs.

# Power part wiring diagram

## ATV-68C10N4 to ATV-68C33 N4

Example of wiring diagram with circuit-breaker and contactor

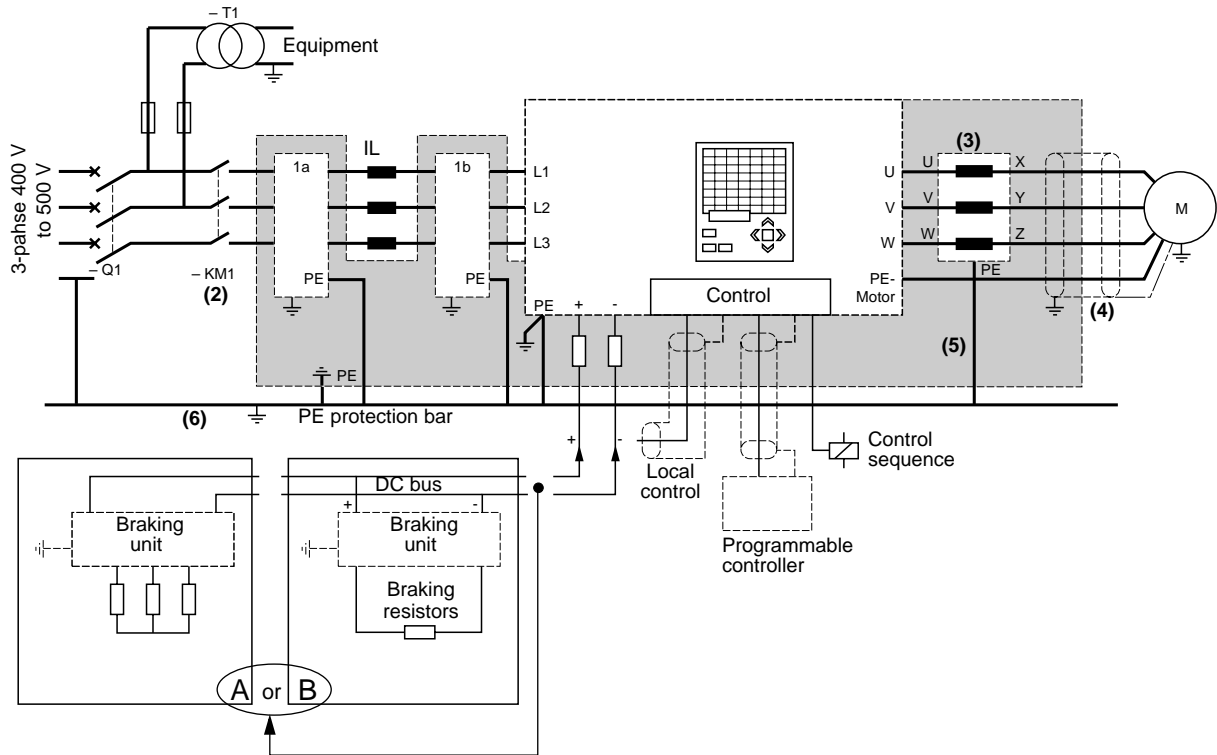

## ATV-68C43 N4 to ATV-68C68N4

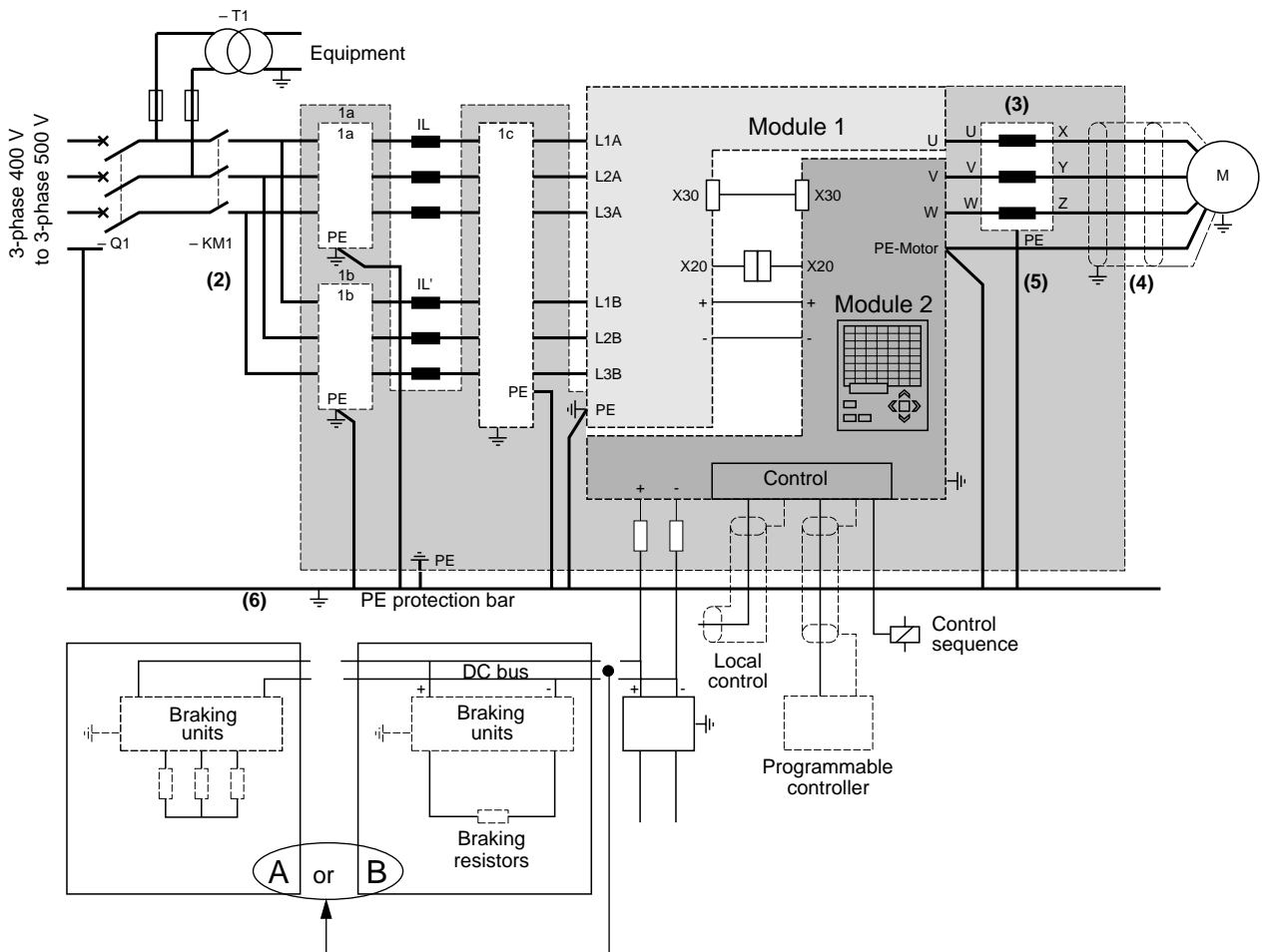

IL and IL' chokes for ratings C43 to C63N4 are always mandatory.



# Power part wiring diagram

## Speed controller upstream supply

Q1 Main circuit-breaker

### Circuit-breaker adjustment

Tripping threshold

$$I_r = 1.1 I_n \text{ motor}$$

Against short-circuits (short-time delay)

$$I_m = 1.5$$

$$T_m = 60 \text{ sec (1)}$$

$$I_{2t} = \text{off (1)}$$

Against short-circuits (instantaneous)

$$I = 2$$

(1) Provided that these settings are included on the release.

### Warning:

Speed controllers are fitted with overcurrent and short circuit protection. It is therefore probable that if line thermal protection has operated, this is due to a speed controller fault. This should be verified before restoring power.

- Power wiring should be using 4-conductor cables or individual cables as close as possible to the PE cable.

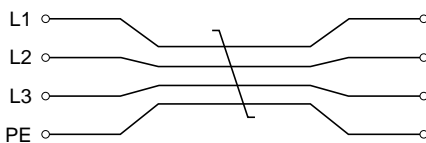

IL, IL' Line chokes mandatory, if impedance is less than:

- 245  $\mu\text{H}$  for rating C10 N4

- 120  $\mu\text{H}$  for ratings C13 - C19 N4

- 60  $\mu\text{H}$  for ratings C23 - C33 N4

or if other speed controllers are connected directly to or very close to the power input of the speed controller (see "Preliminary recommendations").

(1a), (1b), and (1c) Radio interference suppression filters if required. Their connection to line chokes IL and IL' should be as short as possible.

### Note for 500 V filters:

On ratings C10N4 to C33N4, the filter is one section at 1b.

On ratings C43N4 to C68N4, there are two identical filters. One is connected at 1C to L1A L1A L3A and the other at 1C to L1B L2B L3B. The filter and speed controller ground wiring must be at potential equal to the high frequency low impedance links (fixing on unpainted metal sheet with anti-corrosion treatment/machine ground wiring). The filter should be mounted as close as possible to the speed controller.

(2) Optional contactor.

- Avoid switching the contactor KM1 frequently (risk of premature ageing of filter capacitors). Instead use the speed controller locking function.

- In the case of cycles < 60 sec, these arrangements are imperative, to avoid risk of destruction of the capacitor load card.

## Speed controller upstream power supply

(3) Additional motor chokes (optional) for long motor cable lengths (> 50 metres shielded or 80 metres unshielded).

(4) Motor cable shielding is necessary if the environment is sensitive to radiated interference. Regarding the speed controller, fix and ground shielding to the machine ground wiring using 360° contact stainless steel collars.

The main function of motor cable shielding is to limit radio frequency radiation. Therefore use a 4-pole cable for the motor, connecting each end of the shielding observing HF codes of practise. The protection material (copper or steel) is of less importance than the quality of connection at the ends. An alternative is to use a metal trunking of high conductivity ensuring continuity throughout.

### Note:

When a cable with protective covering is used (type NYCY) that performs the double function PE + shield, it is necessary to ensure correct connection to the speed controller and motor side (Its efficiency against radiation is reduced).

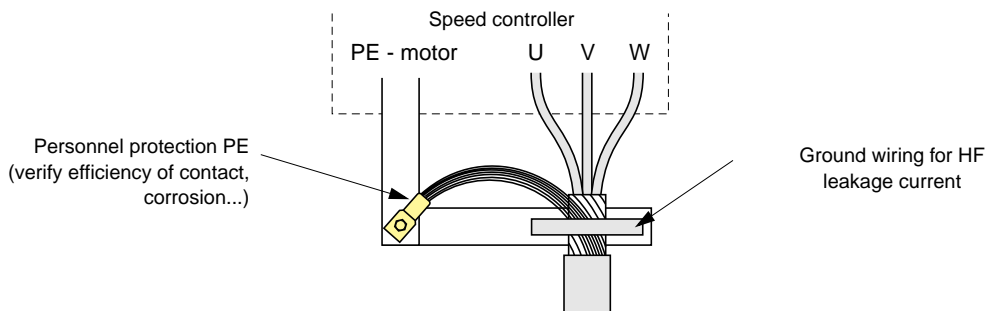

- If the safety standards require motor isolation, provide a contactor at the speed controller output and lock the speed controller when the contactor is not closed.



# Power part wiring diagram

## Wiring and mounting precautions

- (5) Important: conductive mounting plate (in stainless or galvanised steel) for connection of motor cable shielding ground wiring and to ensure ground equipotential between filter, speed controller and shielding.  
All connections should be marked --- representing the EMC equipotential necessary for the flow of HF interference: protection connections, connection of shielding ground wiring to mounting plate and interconnection of shielding. They necessitate low impedance at high frequencies; these are ground wiring or, when this is not possible, large cross-section braiding, (braid) of lengths as short as possible. They can be in parallel with the normal protection conductor (green/yellow) which provides safety.
- The controls, line power supply and output to motor should be as far apart as possible.

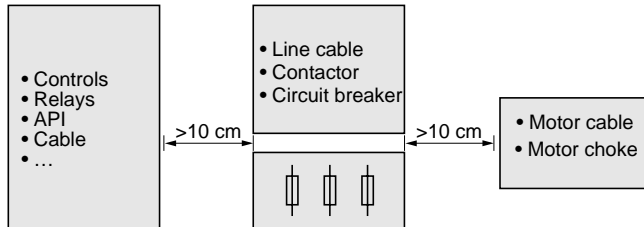

- Any free cores close to the motor cables should be connected to motor PE and speed controller PE, so as to avoid any electrical risk for the user.
- Never install control, line and motor cables in the same ducting.
- If crossing of a control cable by a power cable cannot be avoided, this should be done at a right angle.

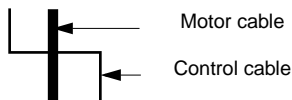

- Use shielded control cables only (exception: relay contacts and possibly logic inputs if these are insulated from power cables). Their shielding should be earthed at each end (exception: when there are loop problems caused by balancing currents which heat the shielding, connect only to the signal input end or install a balancing conductor in parallel).

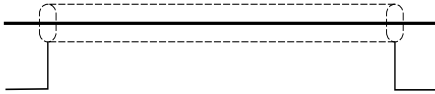

- (6) The speed controller should be earthed by the PE terminal using a cable of section 10 mm<sup>2</sup> minimum. The integrated short circuit to earth protection system does not act as a current limiter. This being so, it protects only the units and not personnel.



### Warning:

The speed controller heat sink should never be connected to the machine ground wiring or earth.

Leakage currents of 500 mA and higher are frequent with medium length cables. Leakage current increases with:

- length of motor cables,
- shielding of these cables,
- switching frequency,
- presence of radio frequency filters,
- motor disturbances.

# DC bus power connection diagrams

## DC bus connection between speed controllers of different rating

### Use of external load card VW3A68180

This connection diagram is recommended for applications in which the speed controllers function in regeneration (braking mode), while one or several others function in drive, eg: winders, directional machines, test benches, conveyors, hoists, etc.



At no time should motor power exceed the limit preset for the standard torque ATV 68 rectifier. (ATV-68C23N4: 200 KW + 20% for 60 seconds).

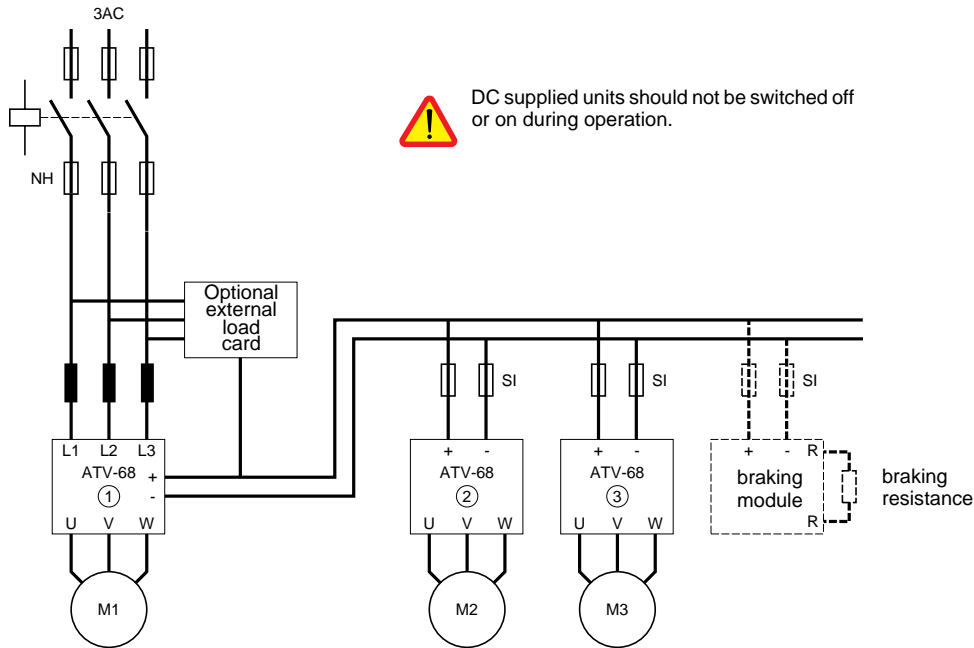

① Standard frequency controller.  
The ATV-68, connected directly to the mains supply, determines the maximum motor power possible for the assembly M1 + M2 + M3.

External load card "Load circuit" option. This option is necessary to avoid overload of ATV 68 load circuits.  
The external load option enables loading of the speed controller for a total power of 500 kW. (Standard torque, ① + ② + ③).

② ③ DC supplied speed controllers. Protection should be carried out conforming to the chapter "DC bus connection cable sections and fuses" using quick blowing fuses. Contactors on the DC circuit are of no use because switching action can cause destruction of the fuses (high load current).

Braking module Braking device and braking resistance if necessary+

# DC bus power connection diagrams

## DC bus connection between speed controllers of the same rating (of same size)

DC coupling is recommended in applications for which full motor power must be guaranteed, while generator operation caused by DC link energy exchange must also be possible (eg. conveyor, etc...).

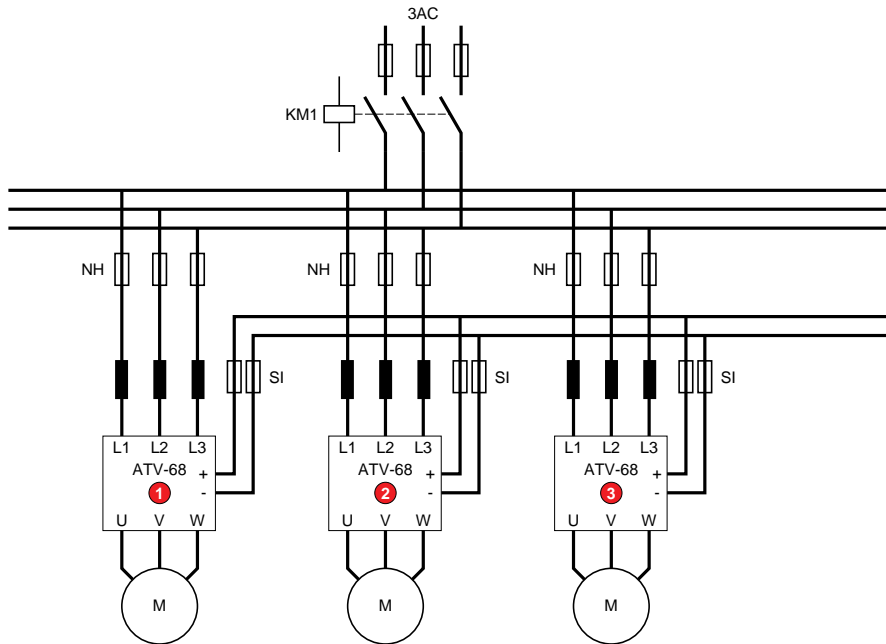

**KM1** Using a common line contactor, all ATV 68 load circuits function in parallel and so can not be in an overload condition.



If one contactor per speed controller is used, the "external load circuit" option should be connected to each speed controller.

**NH**

Line side protection device. For speed controller overload protection, carefully follow the recommendations in the chapter "Line cable sections and fuses". Using fuse supervision (acting on the "external fault" logic input or on the line contactor) resultant damage to the load circuit at switch-on can be avoided.

**SI**

Select fuses for the DC link according to the chapter "DC bus connection cable sections and fuses".



All fuses (NH + SI) should be in service before switching the KM1 contactor.

①②③ **ATV-68 speed controller.**

Generally the number and size of speed controllers can be freely selected, but only speed controllers of the same size or the next size can be associated. Line chokes are mandatory.

# DC bus connection cable sections and fuses

## DC bus power supply

For location of + and - terminals, see "Access to terminals".

### DC connection diameter

- ATV-68C10N4: Terminal connection maximum capacity: 95 mm<sup>2</sup> maximum
  - ATV-68C13N4 to C19N4: M10 connection screw (tightening torque: 40 Nm)
  - ATV-68C23N4 to C63N4: two M10 connection screws with washer (tightening torque: 40 Nm)
- For rating C10N4, DC bus connection is direct on terminal.  
For ratings C13N4 to C63N4, option VW3 A68 802 should be used - DC bus connection kit.

Line supply	For voltage 400 V	For voltage 440 V	For voltage 460 V	For voltage 500 V
DC rated voltage Min...max. voltage range (DC) Overvoltage	560 V DC 430...650 V 1.60 x Un DC	622 V DC 505...684 V 1.45 x Un DC	680 V 530...745 V 1.32 x Un DC	710 V DC 540...790 V 1.27 x Un CC
Rated current (if speed controller supply is by DC bus only)	approx. 1.15 x I motor	approx. 1.15 x I motor	approx. 1.15 x I motor	approx. 1.15 x I motor
Fuse type, rated voltage	sf 690 V	sf 800 V	sf 800 V	sf 800 V

Fuse size Si (1)	Cable section in enclosure (2)	For 400 V and 440 V	For 460 V and 500 V
200 A	70 mm <sup>2</sup>	–	ATV-68C10N4
250 A	95 mm <sup>2</sup>	ATV-68C10N4	ATV-68C13N4
315 A	120 mm <sup>2</sup>	ATV-68C13N4	ATV-68C15N4
400 A	185 mm <sup>2</sup>	ATV-68C15N4	ATV-68C19N4
500 A	2 X 150 mm <sup>2</sup>	ATV-68C19N4	ATV-68C23N4 ATV-68C28N4
630 A	2 X 185 mm <sup>2</sup>	ATV-68C23N4	ATV-68C33N4
800 A	2 X 185 mm <sup>2</sup>	ATV-68C28 / C33N4	ATV-68C43N4
1000 A		ATV-68C43N4	ATV-68C53N4
1250 A		ATV-68C53N4	ATV-68C63N4
1600 A		ATV-68C63N4	



(1) Only quick blow fuses (semiconductors) are admissible for DC application. Due to their design, they can interrupt DC and AC voltages very rapidly.

(2) Values listed are for guidance only.

#### Note:

When an external braking unit is used, adjust C1-03 parameter on 1 (external braking unit).

# Line cables and fuses

The integrated earth fault monitoring module has no current limitation effect. It serves to protect the speed controller only and **not** personnel.

## For speed controller ATV-68C10N4 to C63N4 - 400 V - 440 V

Line			Speed controller			Motor
Speed controller protection line fuse (4)	$I^2t$ (6)	Cable section in enclosure (per phase) in mm <sup>2</sup> (1)	ATV-68 /	Maximum rated current (standard torque)	Connection (1)	Motor cable mm <sup>2</sup> and voltage loss/100 m with max. In (3) (4) (1) (2)
200 A	A	70	C10N4	170 A	Terminal 95 mm <sup>2</sup>	3 x 95 / 5.3 V
250 A	B	95	C13N4	206 A	bolt M10	3 x 120 / 5.2 V
315 A	B	120	C15N4	250 A		3 x 185 / 4.1 V
400 A	B	185	C19N4	300 A		2 x (3x120) / 4.9 V
500 A	C	2 x 150	C23N4	390 A	80 x 5	2 x (3x120) / 1.9 V
630 A	C	2 x 185	C28N4	485 A	2 x Ø 13	2 x (3x150) / 4.8 V
(710) 800 A	C	2 x 185	C33N4	570 A		2 x (3x185) / 4.6 V
2 x 500 A (5)	C	2 x 2 x 150	C43N4	740 A	115 X8 /	3 x (3x185) / 4.0 V
2 x 630 A (5)	C	2 x 2 x 185	C53N4	920 A	3 x Ø13	3 x (3x240) / 3.8 V
2 x 800 A (5)	C	2 x 2 x 185	C63N4	1085 A	2 x Ø17	4 x (3x240) / 3.0 V

## For speed controller ATV-68C10N4 to C63N4 - 500 V

Line			Speed controller			Motor
Speed controller protection line fuse (4)	(6)	Cable section in enclosure (per phase) in mm <sup>2</sup> (1)	ATV-68 /	Maximum rated current (standard torque)	Connection (1)	Motor cable mm <sup>2</sup> and voltage loss/100 m with max. In (3) (4) (1) (2)
160 A	A	50	C10N4	136 A	Terminal 95 mm <sup>2</sup>	3 x 70 / 5.8 V
200 A	B	70	C13N4	165 A	bolt M10	3 x 70 / 7.0 V
250 A	B	95	C15N4	200 A		3 x 120 / 5.0 V
315 A	B	120	C19N4	240 A		3 x 185 / 3.9 V
400 A	C	185	C83N4	312 A	80 x 5	2 x (3x120) / 3.9 V
500 A	C	2 x 150	C48N4	388 A	2 x Ø 13	2 x (3x120) / 4.8 V
630 A	C	2 x 185	C43N4	456 A		2 x (3x150) / 4.5 V
2 x 400 A (5)	C	2 x 185	C43N4	592 A	115 X8 /	2 x (3x185) / 4.8 V
2 x 500 A (5)	C	2 x 2 x 150	C53N4	736 A	3 x Ø13	3 x (3x185) / 4.0 V
2 x 630 A (5)	C	2 x 2 x 185	C63N4	868 A	2 x Ø17	3 x (3x240) / 3.6 V

- (1) Recommended values at ambient temperature 40 °C.
- (2) Indicated voltage drop between phases, per 100 m of cable, at maximum rated current.
- (3) Motor cables are dimensioned for maximum rated current at ambient temperature 40°C mounted in free air. When using in Bypass, motor cables should be dimensioned accordingly.
- (4) In the event of tripping, the sf fuses protect the speed controller against secondary damage on the rectifier, load circuit, etc. Line fuses constitute secondary speed controller protection in the event of the failure of electronic protection. However, if these fuses blow, this is because an internal fault in the unit has occurred. Therefore, change of fuses and switching on again will have no effect. The speed controller must be checked.
- (5) 2 x 3 pole fuses as there are two input bridges.
- (6) For rectifier protection in the event of short circuit and particularly for speed controller overload protection, the line fuses should not have values higher than the following  $I^2t$  tripping values:

A	B	C
75.10 <sup>3</sup> A <sup>2</sup> s	245.10 <sup>3</sup> A <sup>2</sup> s	1000.10 <sup>3</sup> A <sup>2</sup> s

**Note:**

To ensure UL conditions use 60/75°C copper conductor only.

## Use with a motor of a power different to speed controller rating

The speed controller can supply motors of power between 20% and 120% of the rated power at standard torque. Verify that the current absorbed by the motor does not exceed the rated current of the speed controller (see table page 5).

## Connecting motors in parallel

The maximum rated current of the speed controller must be greater than sum of the currents of the motors supplied. In this case, external thermal protection by PTC thermistor probes (up to 6 motors) or by thermal relays must be provided.

If total length of motor cables is greater than 50 m (shielded), provide a motor choke.

Parameterize the sum of the motor currents.

For applications requiring high starting torque (conveyor, hoisting), autotuning should be carried out. In this case, the motors should be mechanically coupled, of the same power, and be fitted with the same lengths of cable.

For applications that do not require high starting torque (pump, fan), autotuning is unnecessary. In this case motor powers and lengths of cable can be different.

Each motor can be isolated by a contactor during operation. On the other hand, reconnection of the motor to the speed controller should be carried out using the precautions described below: "Coupling of a contactor downstream of speed controller".

## Coupling of a contactor downstream of speed controller

Coupling in operation is possible if the motor starting current is less than the maximum transitional current of the speed controller.

However in all cases it is preferable to lock the speed controller just before contactor closing, and to unlock it after closing of power poles.

## Connection to a line insulated from earth or of high impedance (IT)

This type of connection is possible, but mounting of optional radio interference suppression filters is prohibited. However, in the case where interference capacity (or filtering capacitors) between supply line and earth is too high, premature ageing of speed controller can occur if there is an earth fault downstream of the speed controller (motor cable or motor fault). For this type of connection, use of insulation fault detection by toroid sensor is recommended, kit VW3A68190.

## Speed controller and drive protection - "Earth fault protection" option VW3A68 190

Depending on circumstances, protection can be selected from the following:

- Separate transformer for each speed controller (eg: 12 pulse supply) → Operation at earth fault on the speed controller output is authorised for a maximum of 1 hour (line chokes and output filters can overheat)
- 1 supply transformer for several speed controllers → "Earth fault protection" necessary, switch-off must occur within 10 minutes
- 1 transformer for entire factory (high capacity) → «Earth fault protection" necessary, switch-off must occur within 2 minutes

# Installation and maintenance

---

## Installation

After having verified connection of the speed controller and its options (consult operating manuals), it is necessary to refer to the programming manual.

This will enable you to select your dialogue language and "macroprogramming" as a function your application type. It will also will give you all factory configurations and customising possibilities and will enable you to run auto-tuning.

## Maintenance



Before any intervention on the speed controller, cut the line supply, wait at least 5 minutes for capacitor discharge and **verify that voltage between + and – terminals is less than 60 V DC.**

**DC voltage between + and - terminals can reach 750 V or 900 V depending on line voltage (400 V or 500 V).**

In the event of an anomaly on installation or during operation, first verify that recommendations relating to environment, mounting and connection have been respected.

## Maintenance

The Altivar 68 does not require preventive maintenance. It is nevertheless recommended that the following be carried out at regular intervals:

- verify state and tightness of connections,
- confirm that the temperature around the unit remains at an acceptable level and that ventilation is adequate,
- dust the speed controller if necessary.

It can be useful to clean the speed controller and heat sinks. Parameter A3.03 can assist in determining the degree of pollution. Temperature can reach 85°C for ratings C10N4 to C33N4 and 92°C for ratings C43N4 to C63N4 at full load, maximum ambient temperature and at 2.5 kHz. If heat sink temperature reaches high levels in conditions less severe than these, cleaning of the heat sink is recommended.

The programming manual will assist you in identifying the type of fault and analysing its cause.



# Options

## DC bus connection kit VW3 A68 802

On ratings ATV-68C13N4 to C63N4, all DC bus connections (braking module) are made at the side (on right or left). To connect cables or flexible bars, the option "DC bus connection" is required. Cable terminations are accessible after removal of side panels. The option comprises one copper-bar (U-shaped), one copper block and the fixing bolts. DC bus connection can therefore be mounted on either side of the speed controller.

### DC bus connection column

Bar version

Round cable version

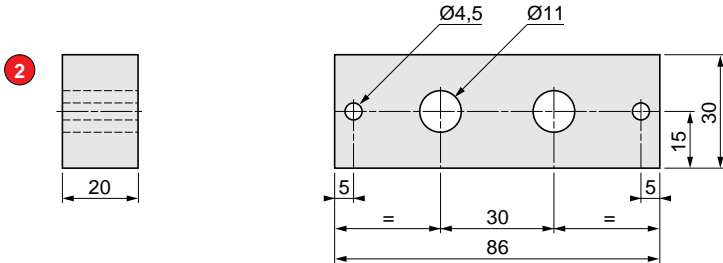
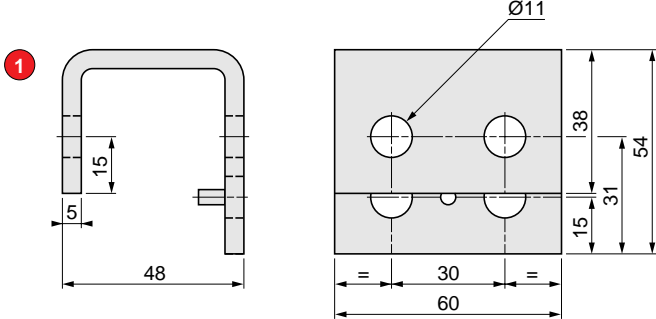
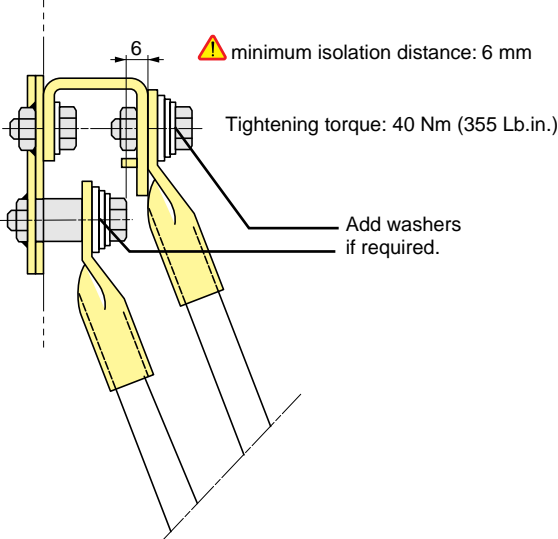
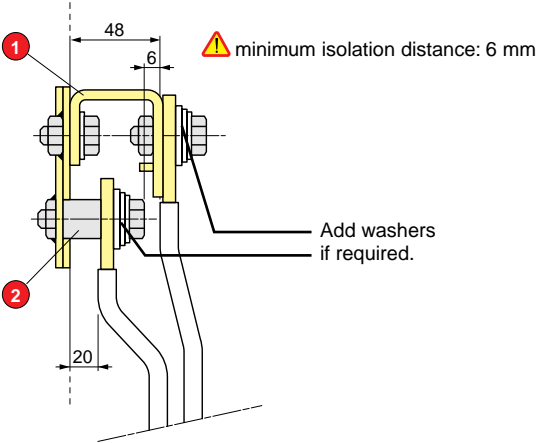

# Options

## External fan 700 - VW3 A68 820 (For enclosure IP23 only)

Use of a ventilation module 700 enables evacuation of warm air from the enclosure for maximum temperatures outside the enclosure of 40/45 °C (see table page 7 and explanation page 12). Additional ventilation ducts are unnecessary.

### Characteristics

- Flow: 1600 m<sup>3</sup> / h
- Rated voltage: 3 AC 400 V, 50 Hz
- Rated current: 1.2 A
- Noise level: 80 dB (A)
- Connection: on junction block for U1, V1, W1 (star connection for U2, V2, W2).

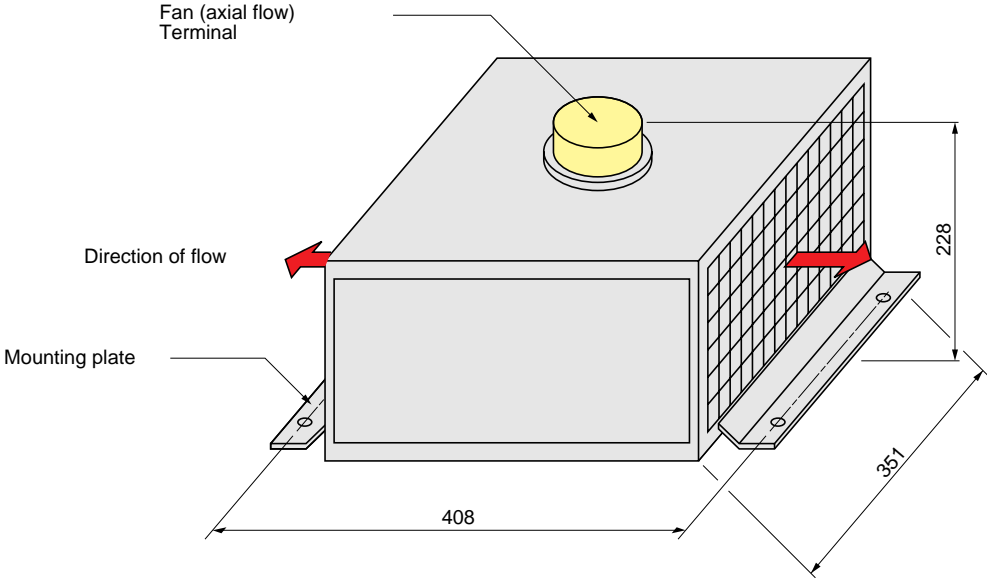

### Drilling guide

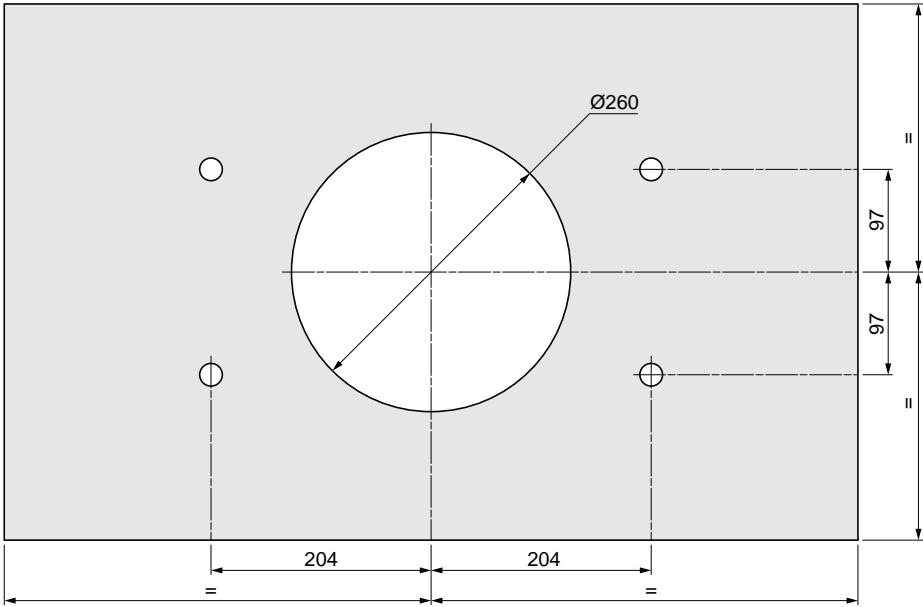

# Options

## Air ducting kit VW3 A68 801 (For IP23 mounting)

This option enables total evacuation of warm air from the enclosure for maximum temperatures outside the enclosure of 35 / 40 °C (see table page 7 and explanation page 13). It is installed on the enclosure cover 85 mm above the upper part of the speed controller.

Ratings C13N4 to C33N4 require 2 air ducting kits (2 kits).

Ratings C43N4 to C63N4 require 4 air ducting kits (4 kits).

To assure IP20 degree of protection, the option is provided with an air grille on the upper part of the ventilation duct.

The kit comprises: 1 air duct, 1 protection grille and fixing screw.

This option does not concern rating ATV-68C10N4 since the speed controller would be located too high in the enclosure. The graphic terminal would be accessible only with difficulty, see chapter "Enclosure installation".

Recommended dimensions 700 x 400 mm  
spacing 60 mm above  
enclosure cover

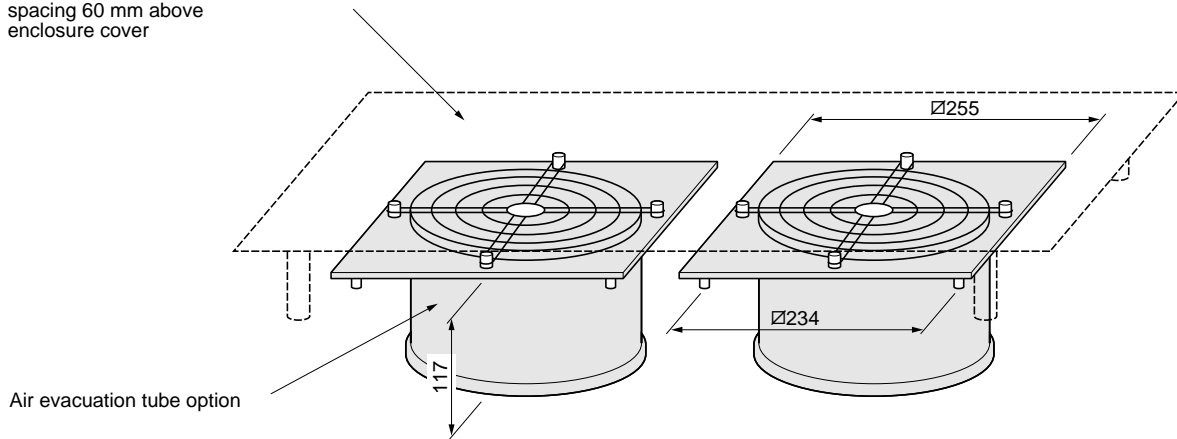

### Drilling guide for enclosure top cover

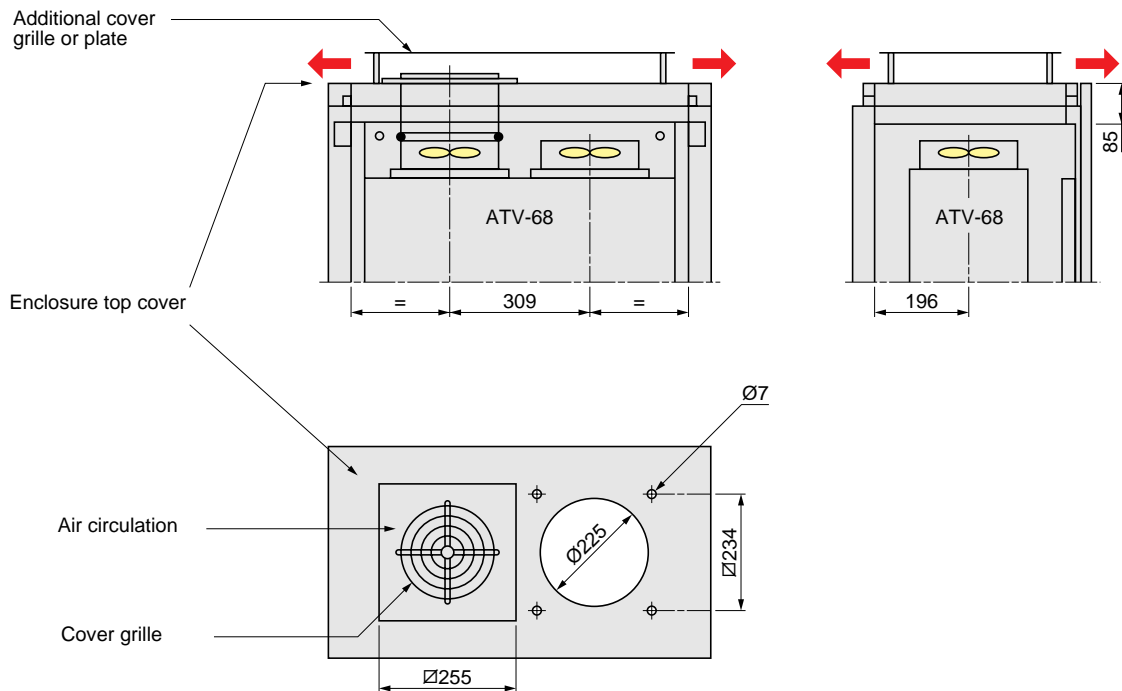

Example: ATV-68C33N4. 2 air ducting kits.

# Options

## Remote operator terminal VW3 A62 800

This option enables remote control of the ATV. It comprises a mechanical support for the liquid crystal display and speed control flat keypad. This panel can tilt and therefore guarantees access to control terminals when the enclosure door is open.

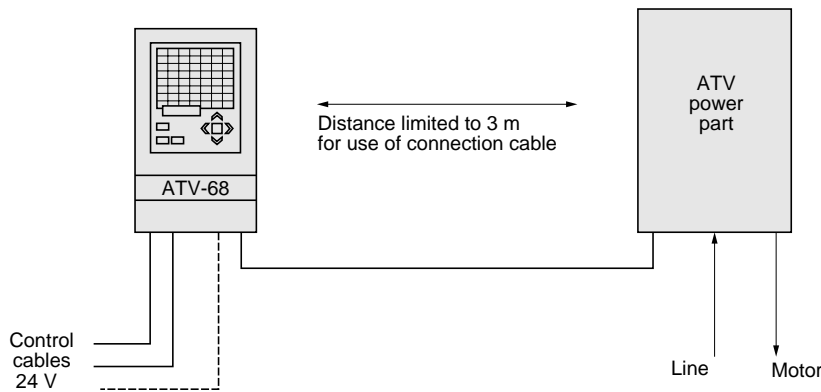

### Drilling guide

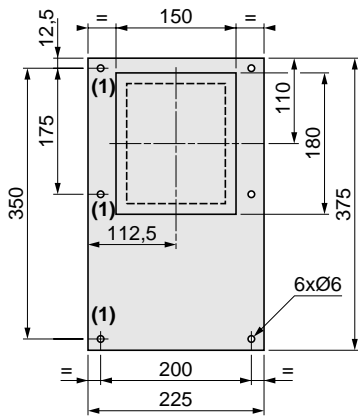

The option is mounted on a metal plate (approx. 2 mm thickness), as for example the door of the enclosure) following the drilling guide (6 holes dia. 6 mm, and an opening 150 x 180 mm).

The tilting interior part projects from the front cover by 20 mm at the bottom. Cables also exit at the bottom.

To mount the option, insert the front cover with its 4 bolts and screw it to the tilting frame.

**(1)** For effective connection of potentials, insert 3 "contact" washers between the enclosure door and the mechanical support of the option (on hinge side).

To carry out electrical connection, the control card, the options cards and the speed control keypad should be dismantled and mounted in the remote mechanical option.

Connection is by the 3 m cable supplied.

The aperture left in the front cover can be covered using the sheet supplied.

The standard VW3A62800 kit is supplied with door mounted on the right.

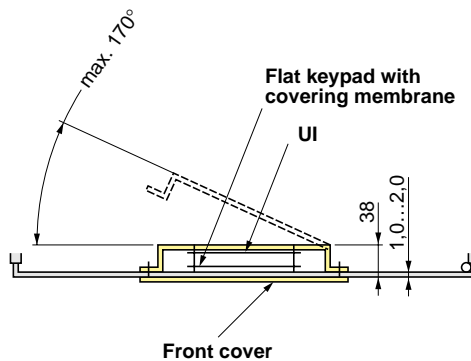
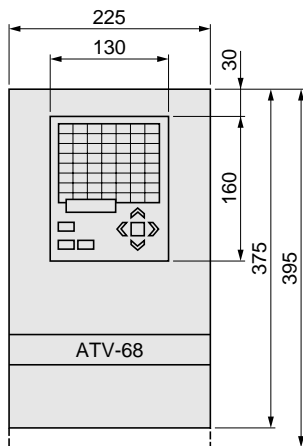

## Earth fault detection kit VW3 A68 190 for IT insulated neutral supply

In IT regime, an earth fault detection device is necessary on the speed controller outputs for its protection in the event of an earth fault. This is described in the chapter "Special uses - IT network". The option uses one of the integrated comparison blocks to evaluate the differential current measured. In the wiring diagram below, the current leakage measured is directed to the logic comparator via the analogue input of the input/output card.

With processing of the analogue input of the input/output card, an "insulation fault" can be programmed on the speed controller. See the programming guide chapter:

- select a comparator in the speed controller function blocks: for example the comparator C1 on F4-03.
- select input AI\_2 as instruction input of comparator F4-00.
- select the basic following instruction input to comparator F4-02
- define action of comparator output - F4-07 at insulation fault
- define at E3-04 the fault acknowledgement mode

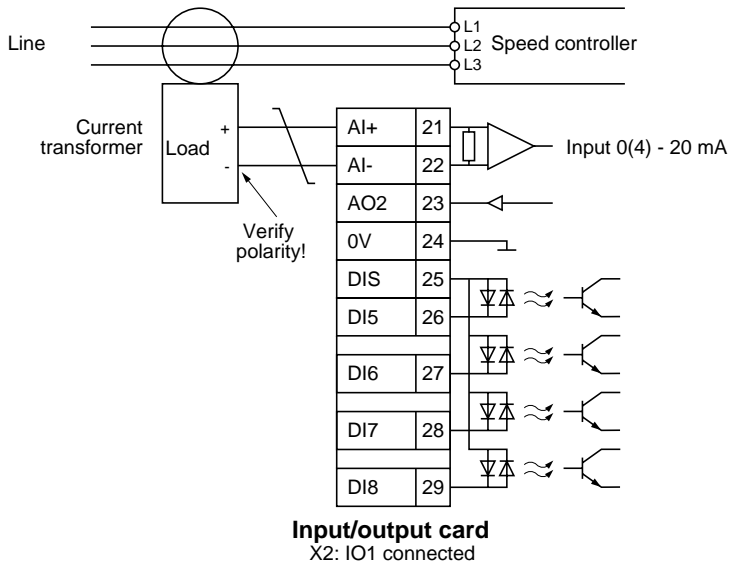

Differential current	Analogue signal (on AI_3)	Internal display
2 A	0.4 mA	2.0%
<b>5 A</b>	<b>1 mA</b>	<b>5.0% (*)</b>
10 A	2 mA	10.0%
20 A	4 mA	20.0%
100 A	20 mA	100.0%

(\*) recommended setting

### Dimensions

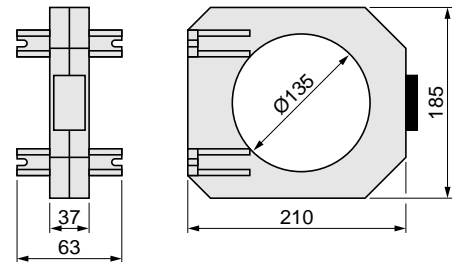

The kit comprises a current transformer with load block .

# Options

## External load circuit kit VW3 A68 180

To avoid overloads and internal circuit failure on speed controllers interconnected by DC bus, it is advisable to use an external load device VW30 A68180 according to the wiring diagram below.

The VW3A68180 option can be used on all sizes of ATV 68 and supports all operating voltages (400 V...500 V). The option can load speed controllers for total power of 500 kW (high torque). Line connection is carried out downstream of a line choke. See also the chapter "DC bus connection".

### Wiring diagram

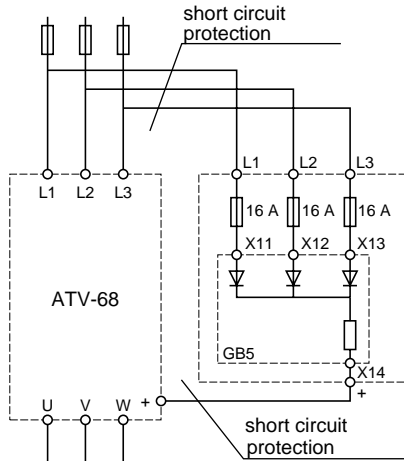

### Dimensions

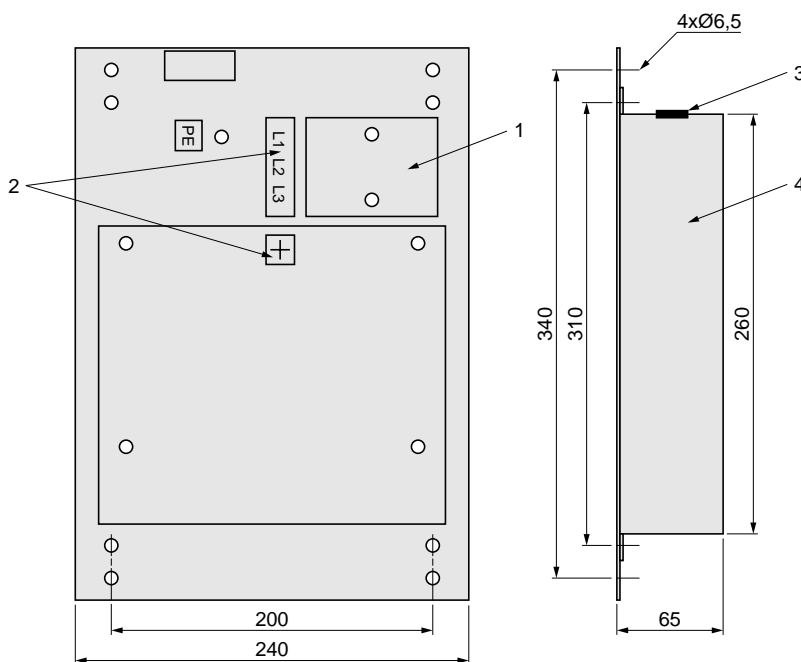

- 1) Fuse (line side) 3 x 16 A
- 2) Line and DC bus connection
- 3) Cable entry
- 4) IP20 metal enclosure

The VW3 A68180 option can be mounted in any position

Thermal dissipation should be carefully taken into consideration (approx. 50 W).

---

